



Fiery JobMaster-Fiery Impose-Fiery Compose

© 2024 Fiery, LLC. The information in this publication is covered under Legal Notices for this product.

19 August 2024

Contents

Fiery JobMaster-Fiery Impose-Fiery Compose	7
Activate the Fiery Impose, Fiery Compose, or Fiery JobMaster license	7
Open a job in Fiery Impose, Fiery Compose, or Fiery JobMaster	7
Open a job group in Fiery Impose, Fiery Compose, and Fiery JobMaster	8
Add a new job	8
Insert pages or image files	9
User interface customizations saved between sessions	9
Set Fiery Impose and Fiery JobMaster preferences	10
About user preferences	10
Choosing Adobe Acrobat Distiller settings for PS to PDF conversion	12
Default scale value	13
Configure default device profile for finisher	14
Adding chapter starts automatically	15
Change the location of user-created imposition templates	15
Check for scanned content	15
Sheet selection	16
PS to PDF conversion	16
PS to PDF conversion on macOS	16
Fiery Impose	18
Access Fiery Impose	18
Make a job spooled or held	18
Access Fiery Impose from Command WorkStation	19
Access Fiery Impose from Job Properties	19
Imposition layouts	19
Understanding imposition layouts	20
Adobe PDF Print Engine processing in Fiery Impose and Fiery Compose or Fiery JobMaster	21
Binding methods	22
Creep	23
Adding blank pages to adjust layout	24
Preview a job for imposition	24
View and measure sheet dimensions	24
View sheets of imposed jobs	25
Imposing a job	25
Imposition templates	26

Support for User Defined and Based on Trim Box finish size templates	26
Apply an Imposition template	28
Save an imposed job	29
Imposition template reference	31
Gangup printing in Fiery Impose	40
Gangup with top finished edge	42
Dynamic trim box automation	43
Best Fit for Gangup Repeat	44
Specify Gangup settings in Fiery Impose	46
Set gangup methods in Fiery Impose	48
Combining gangup styles with gangup methods	48
Specify Layout Row & Column settings for Gangup	49
Gangup imposition methods for VDP jobs	50
Imposition settings	52
Choose a product intent workflow	52
Finish size options for Fiery Impose	53
Set sheet size in Fiery Impose	54
Duplex settings in Fiery Impose	54
Scale settings in Fiery Impose	55
Specify the scale settings	55
Set the cover media	56
Set the layout orientation	56
Bleeds for workflows in Fiery Impose	56
Set bleeds	57
Offset the layout	57
Set margins	57
Set printer's marks in Fiery Impose	58
Specify booklet settings in Fiery Impose	63
Specify binding settings for Booklet	63
Specify row and column settings for booklet product intent	63
Styles available for edge-binding options	64
Specify creep settings	64
Automatic page rotation for imposed, mixed-orientation jobs	64
Modify pages manually in Fiery Impose	65
Rotate pages	66
Open a job for editing in Acrobat	66
Reorder pages	66
Insert blank pages manually	66

Delete pages	67
VDP in Fiery Impose	67
Open or preview a VDP job	67
Imposing a VDP job	68
Print control strips for VDP jobs	68
Specify booklet, scale, or bleeds for VDP imposition	68
Gangup settings for VDP imposition	70
Integration with multi-functional finishing devices	72
Set a registration mark and barcode	72
Apply a finisher preset	72
Create a finisher preset	75
Fiery Compose	85
Setting job options before using Fiery Compose	85
Open and view jobs in Fiery Compose	85
Open a job in Fiery Compose	86
Set the Sheet View to thumbnails or full pages in Fiery Compose	86
Adjust thumbnail size	86
Work with pages in Fiery Compose	86
Open a job for editing in Acrobat	87
Reorder, delete, or set duplex for pages in Fiery Compose	87
Insert a blank sheet or page in Fiery Compose	87
Assign media to pages in Fiery Compose	87
Convert to Grayscale	88
Work with chapter starts in Fiery Compose	88
Set tabs in Fiery Compose	89
Set tab text and other properties in Fiery Compose	89
Set up covers	89
Subset finishing in Fiery Compose	90
Specify a set definition in Fiery Compose	90
Apply subset finishing in Fiery Compose	91
Specify subset finishing for Z-fold in Fiery Compose	91
Save a job in Fiery Compose	92
Fiery JobMaster	93
Job Summary in Fiery JobMaster	93
Filter pages in the Job Summary pane	94
Select Pages by Range	96

Shift the content of a page or pages	96
Open the Scale Content pane	97
Page-level options in the Scale Content pane	97
Inserting image files into Fiery JobMaster	99
Edit a scan in Fiery JobMaster	99
Edit a page in Fiery JobMaster	100
Edit Page workflow	101
NCR multi-part pad printing workflow	104
Advanced Page Numbering and Stamping	105
Advanced page numbering workspace	106
Add a page range	107
Edit a page range	108
Set Advanced Page Numbering options	108
Add an image stamp	110
Resize and reposition the stamp	110
Set the print options for the stamp	111
Set the background color for the stamp and adjust the opacity of the background color	111
Fit the image stamp inside the selection box and to adjust the opacity of the stamp	111
Add tabs	111
Insert and edit tabs in Fiery JobMaster	113
Add multiple tab styles to a document	114
Bleed edge tabs in Fiery JobMaster	115
Add content to bleed edge tabs	116
Specify position of bleed edge tabs	116
Image Editing	117

Fiery JobMaster-Fiery Impose-Fiery Compose

Fiery Makeready Solutions use one visual reference to integrate labor-intensive document preparation activities at the sheet and page levels.

Fiery Makeready Solutions consists of the following licensed applications:

- Fiery Impose applies imposition layouts to jobs for custom printing, binding, and trimming. Fiery Impose also applies impositions to variable data jobs and saves imposed jobs as PDF files.
- Fiery Compose allows you to define the chapter divisions of a job, print ranges of pages on varying types of media, insert blank media between pages, and insert tab media containing text labels (if the printer supports tab printing).
- Fiery JobMaster provides advanced PDF-based job preparation tools for scanning, tab creation and insertion, page numbering, chapter creation, and late-stage editing. It includes all functions of Fiery Compose.

Additionally, the following integrated tool is a standard feature in Fiery Command WorkStation:

- Fiery Preview provides a preview of a job, and users can do a soft proof of each sheet surface of a job before it is processed. The visual interface changes dynamically to display any changes made in preparing documents for printing.

Adobe Acrobat Pro is available as a separate kit with a valid Fiery Impose, Fiery Compose, or Fiery JobMaster license. It is recommended that you use the version of Acrobat provided in the kit.

Fiery Makeready Solutions are supported on both Windows and Mac computers. For information about system requirements, see *Configuration and Setup*, which is part of the user documentation set.

Activate the Fiery Impose, Fiery Compose, or Fiery JobMaster license

To activate the Fiery Impose, Fiery Compose, or Fiery JobMaster license, you must have a License Activation Code (LAC). You can activate the license automatically if your computer is connected to the Internet, or manually if your computer is not connected to the Internet.

Note: To upgrade from Fiery Compose to Fiery JobMaster, you must first activate your Fiery Compose license and then activate your Fiery JobMaster upgrade license. Do not deactivate your Fiery Compose after upgrading to Fiery JobMaster. If you deactivate your Fiery Compose, and you attempt to use Fiery JobMaster, a message displays prompting you to reactivate your Fiery Compose license.

- 1 In Command WorkStation, right-click a job and choose **Impose**, **Compose**, or **JobMaster**.
- 2 If you are asked whether to activate the option, click **Yes**.
- 3 For more information, see the *Fiery Client SW License Help* by clicking the ? (Help) icon in the upper-right corner of the License Activation page.

Open a job in Fiery Impose, Fiery Compose, or Fiery JobMaster

After activating your license, you can open a spooled or held job in Fiery Impose, Fiery Compose, or Fiery JobMaster.

Note: When a job is opened in Fiery Impose, Fiery Compose, or Fiery JobMaster, do not open the same job in **Job Properties**.

- 1 Select a PostScript or Adobe PDF job in the **Held** list of Command WorkStation.

If you are working with processed jobs on a Fiery server running Fiery system software version FS200, you must select **Remove Raster** before right-clicking the job and selecting Fiery Impose, Fiery Compose, or Fiery JobMaster. With more recent versions of the Fiery system software, selecting **Remove Raster** is not necessary. After the raster is removed, you must reprocess the job before printing. If you do not want the job to require reprocessing, select **Actions > Preview** and the job will open in a raster **Preview** window.

- 2 From the **Actions** menu, select **Impose, Compose, or JobMaster**.

You can also right-click a job and select **Impose, Compose, or JobMaster**.

To select a single page of a multi-page document, **Option-click** (macOS) or **Alt-click** (Windows) a page in the **Sheet View** pane to select the same page in the **Page View** pane.

If you have activated Fiery JobMaster, for example, you can now acquire scans, edit them, and place them in your job; edit pages and add page numbering; and insert tabs and edit the tabs and the tab text.

Open a job group in Fiery Impose, Fiery Compose, and Fiery JobMaster

After you have activated your license, you can also start to use Fiery Impose, Fiery Compose, or Fiery JobMaster to open a job group.

Note: Only PDF Groups are supported on Fiery Impose, Fiery Compose, and Fiery JobMaster.

For more information on creating a job group, see *Fiery Command WorkStation Help*.

- 1 Right-click a PDF Group.
- 2 From the Actions menu, select **Impose, Compose, or JobMaster**.

You can also right-click a job and select **Impose, Compose, or JobMaster**.

Add a new job

You can create a blank new job in Fiery Impose, Fiery Compose, or Fiery JobMaster.

You must have Fiery Impose, Fiery Compose, or Fiery JobMaster licensed on your computer to create a new job. You cannot create a new job in Fiery Impose demo version.

For example, you can create a job entirely in Fiery JobMaster, including tab and scan jobs. This is useful when you do not have any digital content already stored on the Fiery server.

- 1 Click the **New Job** icon in the Command WorkStation tool bar, or select it from the **File** menu.
Your new job opens in either Fiery Impose, Fiery Compose, or Fiery JobMaster, depending on the license activated on your computer.

- 2 Apply settings as required.
- 3 Insert pages from an existing job, if required.
You can only insert pages from the source PDF document. You cannot insert pages that were previously added as inserted tabs to that job.

Insert pages or image files

You can insert pages from a job on the Fiery server, or from your computer. In Fiery JobMaster, you can insert image files, or insert pages from a scanner.

- 1 To insert a file, do one of the following:
 - Click **Actions** > **Insert PDF or PS File**.
 - Click **Actions** > **Insert Server Job**.
 - In Fiery JobMaster, select **Insert Image Files** or **Insert From Scanner** from the **Insert** menu.
- 2 Do one of the following:
 - Browse to the location of the file and click **Open**.
 - For a server job, click the file in the list and click **OK**.
- 3 Do one of the following:
 - In the **Insert Pages** window, choose where to insert the new pages. Select **At Start of Job**, **At End of Job**, **After Page**, or **Before Page**, and click **Insert**.
 - To insert specific pages, drag the pages to the **Page View** pane and arrange them in the order you want.

User interface customizations saved between sessions

The system saves user interface customizations separately for each product intent: Fiery Impose, Fiery JobMaster, Fiery Compose, and Raster Preview.

For each of these product intents, the user interface customizations are saved between sessions. When you open a new session in that same product intent, customizations from the previous session are restored, including:

- position and size of the main window
- user interface settings inside the window, including:
 - sizes of the **Page View**, **Sheet View**, and (for Fiery JobMaster) **Job Summary** panes
 - expanded or collapsed state of collapsible panes in **Page View**, **Sheet View**, and (for Fiery JobMaster) **Job Summary** panes
 - zoom level of **Page View** thumbnails and **Sheet View** pages

Note: The system saves your customizations for your initial product intent. When you close Fiery JobMaster, Fiery Impose, or Fiery Compose, the settings to be restored are saved for that product intent, and are applied the next time you open that product intent. Customizations are not applied when you switch between product intents, such as between Gangup (an Impose mode) and Compose. Customizations saved for one product intent (for example, Compose) are not applied the next time you launch another product intent (for example, Impose); instead, the applied customizations for Impose are from the previous time you closed Impose.

When you open Raster Preview, the image area is scaled to fit. Persistent settings in Raster Preview mode are:

- size and location of main window
- window maximized or restore state
- **Page View** thumbnails collapsed or expanded state, zoom level, and pane size

Set Fiery Impose and Fiery JobMaster preferences

Preferences lets you set the path to temporary files, defaults for converting PostScript to PDF, scaling, the default finish size for imposed jobs, and more.

In Windows, you set Fiery Impose and Fiery JobMaster preferences in **Edit > Preferences**. On macOS, preferences are under the **Fiery Command WorkStation** menu within the Fiery Impose or Fiery JobMaster window.

To use dark mode on a Mac computer, make a setting in Fiery Command WorkStation preferences. For more information on dark mode, see *Fiery Command WorkStation Help*.

About user preferences

To select user preferences, select **Edit > Preferences**.

Under **General**, do any of the following:

- Select the default settings for PS to PDF conversion.
- Allow multitasking with Fiery Command WorkStation.

Under **Impose**, do any of the following:

- Select the default finish size for imposed jobs.
- Select the default scale values for imposed jobs.
- Specify the imposition template path.

Under **JobMaster**, do any of the following:

- Specify whether to add chapter starts to files dropped into Page View
- Specify whether to check PDF documents for scanned content
- Specify whether to show the scanned content message
- Specify the default application used to edit images in Fiery JobMaster

Under **Finishers**, do any of the following:

- Select the **Allow finisher integration** check box to enable the finisher integration workflow using which you can apply, create, and publish finisher presets.

When you select **Allow finisher integration**, the following are enabled:

- **Apply Finisher Preset** option in the **Actions** menu.
- **Finisher Preset** button in the **Settings** pane.

Note the following:

- If a finisher is not used, you can clear this check box.
- **Allow finisher integration** does not apply to finishing devices that support only setting a registration mark and barcode.
- **Select device** - Select the finishing device from the list.

Depending on the finishing device that is selected, you can perform one or a combination of the following tasks:

- [Set a registration mark and barcode](#) on page 61
- [Apply a finisher preset](#) on page 72
- [Create a finisher preset](#) on page 75

Note: Tasks are device-dependent, and you can perform these tasks only if supported by the selected finishing device.

After specifying settings in the **Finishers** tab, restart the application to apply the changes.

If you have selected a finisher, specify the following additional settings:

- **PC controller path** - The path to the installation folder on the Duplo Controller computer. Click **Test** to test the connection between the Fiery server and the computer with the Duplo PC Controller software.
- In the Available finisher module section, you can select any of the following, depending on your finisher:

Finisher module	Description	Supported finisher
CPM	The Cross Perforation Module (CPM) is an optional module installed on the finisher to support horizontal or cross perforation and horizontal scoring. Perforation is performed parallel to the feeding edge. If the job requires horizontal perforation, a minimum of one CPM module must be available for use on the finisher. To perform horizontal perforation, you must select the number of modules available on the finisher.	<ul style="list-style-type: none"> • Duplo DC-618
CPM	The Cross Tool Module (CPM) is an optional module installed on the finisher to support horizontal or cross perforation. Perforation is performed parallel to the feeding edge. If the job requires horizontal perforation, a minimum of one CPM module must be available for use on the finisher. To perform horizontal perforation, you must select the number of modules available on the finisher.	<ul style="list-style-type: none"> • Duplo DC-648

Finisher module	Description	Supported finisher
CRM	The Creaser Up Module (CRM) allows crease up (mountain), in addition to standard crease down (valley), horizontally across the sheet.	<ul style="list-style-type: none"> • Duplo DC-648
OSM	The Optional Slitter Module (OSM) provides up to 8 slits per sheet in combination with standard slitter modules.	<ul style="list-style-type: none"> • Duplo DC-648
PFM	<p>In the PFM (Perforation Module - Vertical) module, perforation is performed in the direction that is perpendicular to the feeding edge. If the job requires vertical perforation, a minimum of one PFM module must be available for use on the finisher.</p> <p>To perform vertical perforation, you must select the number of modules available on the finisher.</p>	<ul style="list-style-type: none"> • Duplo DC-618
RTM	RTM or the Rotary Tool Module is an advanced vertical perforation unit that can perform two perforations at a time on the right and the left side of the printed output. A maximum of two RTMs can be installed on one finisher.	<ul style="list-style-type: none"> • Duplo DC-618 • Duplo DC-648

- **Barcode range** - The minimum and maximum barcode range.

Under **Cache**, do any of the following:

- Select **Enable caching** to allow Command WorkStation to store information locally.
- Specify the cache path.

Choosing Adobe Acrobat Distiller settings for PS to PDF conversion

In Windows, select **Edit > Preferences > General** to choose Adobe Acrobat Distiller settings for converting PostScript files to PDF. On macOS, preferences are under the **Fiery Command WorkStation** menu within the Fiery Impose or Fiery JobMaster window.

Select **Use server conversion, if supported** to allow the Fiery server to convert the jobs on the server rather than on the user computer, and to select the PDF setting that you want to use. Select **Use default server settings** to allow the Fiery server to use its own default profile.

Select **Use selected job options file** to allow users to browse and upload their own profile. Server conversion is often faster than downloading the file to the client computer for conversion, and then re-uploading it to the Fiery server afterward. However, this option is not recommended in the following scenarios:

- Licensed fonts, which are installed only on the user's computer, are required for conversion.
- If a newer Adobe Acrobat version is available, the conversion must be done with the newer version to support the new Acrobat features.
- You want to ensure that the Fiery server resources are allocated for processing only, not for file conversion.
- Users may be connected to a previous version of the Fiery server, which does not support server side conversion.

Default scale value

For the **Based on Crop Box** finish size, **Default scale values for imposed jobs** can be either **Do not scale** or **Scale to fit**.

For the **User Defined** finish size, **Default scale values for imposed jobs** can be any of the following:

- **Do not scale (100%)**
- **Fit finish size proportionally**
- **Fill finish size proportionally**
- **Fit bleed size proportionally**
- **Fill bleed size proportionally**

In the diagrams, the red dotted line shows the finish size, and the green dotted line shows the bleed size.

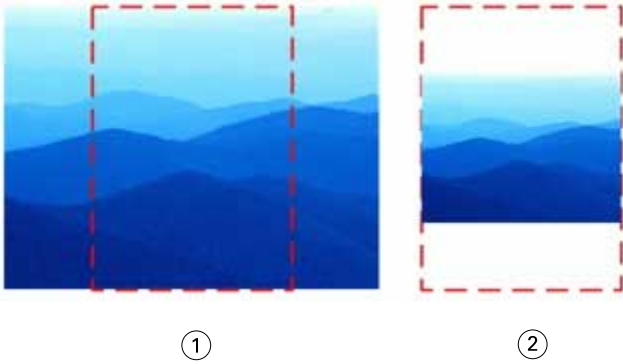

1 *Fill*

2 *Fit*

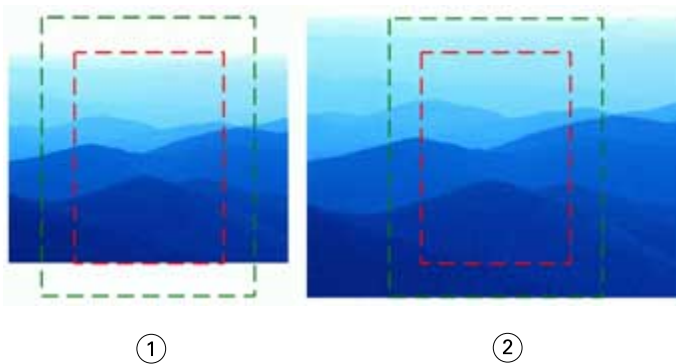

1 *Fill finish size*

2 *Fill bleed size*

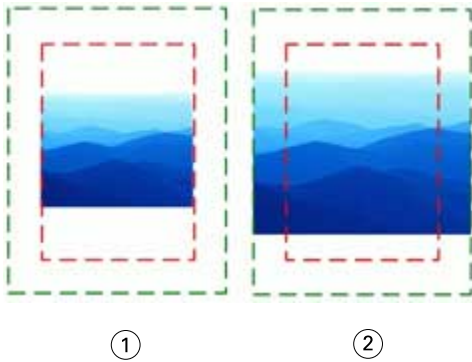

- 1 *Fit finish size*
- 2 *Fit bleed size*

Set imposition scale and finish size

In **Preferences > Impose**, **Default scale values for imposed jobs** sets the default scale factor when Fiery Impose starts. **Finish Size** is based on the PDF crop box or trim box settings.

- 1 For **Finish Size**, click **Based on Crop box** or **User Defined**.
 - **Based on Crop Box**, the default and legacy Fiery Impose workflow, depends on the PDF crop box.
 - **User Defined** allows Impose to detect the trim box settings, when present within the document, and use these as the default finish size. It does not depend on document size and crop box.
- 2 For **Default scale values for imposed jobs**, choose a scale setting as described in [Default scale value](#) on page 13.

Configure default device profile for finisher

You can select a finisher device profile to define default barcode format and registration mark type.

Duplo finishers that support three-digit barcodes extend the number of total programmable jobs to 250. A programmable job is a customized cut, slit, or fold program based on gangup layout.

Note: A finisher configured for three-digit barcodes accepts the range 1-99 as 001-099 and not as 01-99.

- 1 In Windows, select **Edit > Preferences**. On macOS, preferences are under the **Fiery Command WorkStation** menu within the **Fiery Impose** or **Fiery JobMaster** window.
- 2 Click the **Finishers** tab in the column on the left.
- 3 In the **Finisher configuration** section, select the desired profile of the finisher from the **Select device** list.

Note: When you change between barcode formats, any previously saved jobs or Impose templates are not affected.

Adding chapter starts automatically

You can add chapter starts by dragging and dropping files into Fiery JobMaster. You can also set a preference to not add chapter starts.

A chapter start is automatically added to the first page of the added file, when you drag a file onto **Page View** in the **Fiery JobMaster** window. When multiple PDF files are inserted, the chapter start is added to the first page of each PDF file.

Note: If you do not want a chapter start added, insert the file using the **Insert** menu.

Note: In Windows, to set a preference to not add a chapter start, select **Edit > Preferences**. On macOS, preferences are under the **Fiery Command WorkStation** menu within the **Fiery Impose** or **Fiery JobMaster** window. In the window, select **JobMaster** in the left column. Under **Chapter Starts**, clear the check box next to **Add chapter start when dragging file into page view**.

Change the location of user-created imposition templates

You can change the location where Fiery Impose stores user-created imposition templates.

You control where Fiery Impose loads user-created imposition templates (after closing and re-opening Fiery Impose), and where the templates are stored when the user saves one.

Note: You cannot hide the stock templates; they are always shown.

- 1 In Windows, select **Edit > Preferences**. On macOS, preferences are under the **Fiery Command WorkStation** menu within the **Fiery Impose** or **Fiery JobMaster** window.
- 2 From the column at the left, select **Impose**.
- 3 Click **Browse** and navigate to the desired folder.
- 4 Click **Select Folder**.

Check for scanned content

By default, when you insert a PDF document into Fiery JobMaster, the document is checked for scanned content.

If inserted PDF documents contain scanned content and if the preference for checking scanned content is enabled, a message asks whether you want to review and edit the scanned images. Only pages that contain scanned images are presented to you for editing. However, both checking for scanned content and showing the scanned content message are preferences that you can turn off.

Note: If you drag-and-drop a document onto Page View, Fiery JobMaster does not check the document for scanned content.

- 1 In Windows, select **Edit > Preferences**. On macOS, preferences are under the **Fiery Command WorkStation** menu within the **Fiery Impose** or **Fiery JobMaster** window.
- 2 From the column at the left, select **JobMaster**.
- 3 Clear the **Check inserted PDF documents for scanned content** check box.

4 Clear the **Show scanned content message** check box.

If the **Check inserted PDF documents for scanned content** check box is cleared, then regardless of the setting of **Show message**, the scanned content message will not be shown because Fiery Impose does not know that there is scanned content.

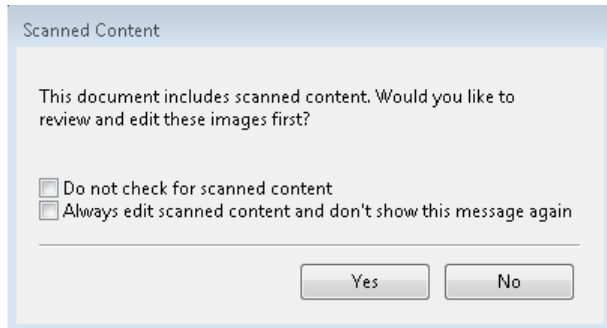

Sheet selection

The sheet range edit box in Sheet View allows you to input a sheet number to navigate to a specific sheet.

PS to PDF conversion

The native format of Fiery Impose, Fiery Compose, Fiery JobMaster, or Fiery Preview is PDF. If a PostScript file is open in one of these applications, the **PS to PDF Conversion** converts the job to PDF before any other actions are performed. When you save the opened PostScript job, the PDL of the saved job appears as a PDF in the Held list.

To turn on the **PS to PDF Conversion** option, go to the **General** tab of **Preferences**. Select **PS to PDF Conversion**.

When **Use server conversion if supported** is selected, you may choose either **Use default server settings** or **Use selected job options file**.

Note: Adobe Distiller must be installed on the server to use default job option settings.

When you choose **Use selected job options file**, click **Browse** to view available files. If Adobe Distiller is installed on the client, you may select any job option installed in Adobe Distiller job options folder.

PS to PDF conversion on macOS

You must grant permission to Command WorkStation to access Acrobat Distiller to convert PS files to PDF.

When you open a PS file in Fiery Impose, Fiery Compose, or Fiery JobMaster for the first time, click **Allow** in the window to grant permission to Command WorkStation to allow Acrobat Distiller to perform the conversion.

If you deny permission, current and future conversions will fail. To enable conversion, you will need to make changes in the **Security & Privacy** window.

- 1 Close all Fiery applications.
- 2 Close Adobe Acrobat Distiller.
- 3 Go to **System Preferences > Security & Privacy > Privacy > Automation**

- 4 Click the lock icon in the bottom-left corner and enter your password.
- 5 In the list of applications, find **Fiery Command WorkStation.app**.
- 6 Select **Acrobat Distiller.app** to enable Command WorkStation to access Acrobat Distiller.

Fiery Impose

Fiery Impose applies imposition layouts for special printing and binding needs. You can also impose variable data printing jobs when you use Fiery Impose. You can use predefined layouts for common impositions or create custom layouts.

You can do any of the following in Fiery Impose:

- Place multiple pages on a single sheet
- Specify how many rows and columns of pages to lay out on a sheet
- Set the placement of pages on a sheet
- Define the location of folds, cuts, and other elements with printer's marks

Note: If you have a license for Fiery JobMaster, you can also apply advanced job preparation tasks to your job in the same workflow.

Fiery Impose license

The client computer must have an activated Fiery Impose license to use the full functionality of Fiery Impose. Without an activated license, Fiery Impose runs in **Demo** mode, which:

- Applies a watermark to print jobs
- Allows you save imposed jobs in .dbp format to the Fiery server
- Does not save imposed jobs in Adobe PDF format to a hard drive or Fiery server

Access Fiery Impose

You can access Fiery Impose directly from Command WorkStation or from the **Job Properties** window for a selected job.

Note: You can open a PostScript, Adobe PDF (Portable Document Format), or VDP file, but it must show a spooled status.

Make a job spooled or held

A job must be spooled or held to be opened in Fiery Impose.

- Do one of the following:
 - For a processed or held job, select the job in the **Held** list.
If you select a processed or held job and choose **Actions > Preview**, the job opens in the **Raster Preview** window.
 - For a printed job, select the job in the **Printed** list and click **Actions > Hold**.

Access Fiery Impose from Command WorkStation

You can open a job in Fiery Impose directly from Command WorkStation.

- 1 Select a spooled job in the **Held** list of Command WorkStation.
- 2 Click the **Actions** menu.
- 3 Select **Impose**.

Access Fiery Impose from Job Properties

When you open a job in the Fiery Impose window from **Job Properties**, the job appears in wireframe view in the **Sheet View** pane. Fiery Compose settings and product intent controls in the **Settings** pane are not available.

- 1 Do one of the following:
 - Click a spooled or held job in the **Held** list.
 - For a hot folder, click the hot folder in the **Fiery Hot Folders Console**.
- 2 Click **Actions > Properties**.
- 3 Click the **Layout** tab, and then click **Impose**.
- 4 Click **Edit Impose Template**.
If you want to edit the Fiery Impose template to create a custom template, the Fiery server must support Fiery Impose, and you must have the appropriate license.

Imposition layouts

Fiery Impose provides predefined layouts for common impositions such as booklets and brochures. You can also create and save custom layouts.

Fiery Impose supports layouts of up to 625 pages per sheet (1250 pages duplex), in a matrix of up to 25 rows by 25 columns. Further limits may apply depending on the connected Fiery server. **Gangup** printing methods support all layout of rows and columns. Binding methods (**Saddle**, **Nested Saddle**, **Perfect**) support only the 1 x 2, 2 x 1, and 2 x 2 layouts.

The items below all affect the layout of the job.

Duplex printing

Depending on your printer, duplex printing may not be supported or may have a different implementation. Fiery Impose supports duplex printing that corresponds to the available print options.

For more information, see [Duplex settings in Fiery Impose](#) on page 54.

Gutter sizes

Fiery Impose defines the locations of gutters for you according to the layout and sheet size governing the imposition of the job. For example, perfect-bound jobs typically require larger gutters than saddle-stitched jobs, to provide room for trimming off the spines and gluing signatures together when the book is bound.

For more information, see [Set Gutters](#) on page 47.

Setting margins

The size and location of the margin (the area between the outside edge of a group of imposed pages and the edge of the sheet) depends on the printer associated with the job. You cannot set custom margins, but you can use **Scale to Fit** to re-size the content on the sheet. The **Finish Size** setting provides different options for setting the content with regard to the trim size.

Understanding imposition layouts

Fiery Impose arranges the pages of your application-specific file in the correct order and orientation for printing and a variety of binding styles to produce a bound book.

Commercial offset printers and web presses use wide rolls of paper and large printing plates capable of imaging numerous pages on a single sheet. Printers might image up to 32 full-size pages on a single press sheet, a process inherently faster than printing a single page at a time. Fiery Impose allows you to image multiple pages on a single sheet, but the output devices it supports are digital copiers, rather than traditional printing presses. The paper on which a job is imaged is referred to as the sheet.

The printed sheet is folded into something resembling a booklet with connected pages. The folded sheet, called a signature, is then trimmed to the finished size.

For pages to appear in normal reading order and position in the final booklet, their ordering and positioning on the sheet must differ from the normal book-reading order. Some pages must be printed upside down on the sheet in order for them to appear right-side-up in the final booklet, and pages must also be printed out of numerical sequence on the sheet in order for them to appear in the correct numerical sequence in the final booklet.

Make a folding model

You can make a folding model of a signature to show how the pages would be laid out on the sheet and how the sheet would be cut and folded.

- 1 Fold a sheet of standard size paper in half horizontally, so the top edge of the sheet meets the bottom edge.
- 2 Fold the paper again vertically, so the left edge of the sheet meets the right edge.
- 3 Position the signature with the vertically folded edge to the left and the horizontally folded edge across the top.

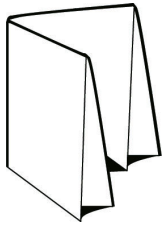

- 4 Page through the folded signature as if it was a book you were reading.
 - a) Number each page sequentially, on both front and back, starting with page 1 on the front (the front cover) and page 8 on the back (the back cover).
 - b) Underline each number to highlight the page orientation.
- 5 Unfold the piece of paper.
 The image below shows both sides of the paper.

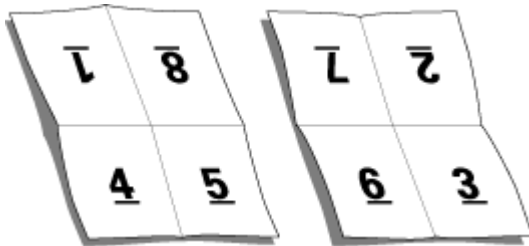

The result is a model of the layout for an 8-page signature. Note the following:

- The folds subdivide the sheet into areas representing pages in the final booklet.
- Page numbers do not appear in book-reading order.
- Some page numbers are upside down.

Adobe PDF Print Engine processing in Fiery Impose and Fiery Compose or Fiery JobMaster

Fiery Impose and Fiery Compose, or Fiery JobMaster support Adobe PDF Print Engine, a PDF-based processor that allows direct processing of PDF jobs without conversion to PostScript.

You can turn on the PDF Print Engine in Configure in Command WorkStation, and you can turn it off on a per-job basis in Job Properties.

If **Sheet Size** is specified through **Mixed media** in **Normal**, **Booklet**, or **Gangup** product intents, then the job is processed through CPSI (Configurable PostScript Interpreter) rather than through the PDF Print Engine.

Note: **Sheet Size** changed in **Compose** product intent is supported.

These restrictions apply for imposed jobs in Job Properties:

- N-up jobs with the **Print border** option
- 1-up Perfect binding jobs inside the **Booklet** layout option
- Variable Data files other than PDF/VT

Jobs using non-supported features are processed through the PostScript interpreter.

Starting with Fiery FS600/600 Pro and later, PDF Print Engine imposition processing is supported for variable data jobs for PDF/VT files with the following exceptions:

- Auto Page Rotation
- Blank Page Text
- Covers
- Creep
- Demo marks
- Duplo binding type
- Mixed page sizes
- Mixed record lengths
- Page range
- Record range
- Sheet range
- Subset Chapters
- Subset Finishing
- Watermarks

Binding methods

A book layout also specifies how sheets are gathered and bound. Three standard methods are saddle stitch, perfect binding, and nested saddle.

The binding method affects the order in which pages are placed on the sheet. Your imposition settings must specify the method by which the finished job will be bound to achieve the correct layout and finished output.

- **Saddle stitch** - Signatures are folded together as a group, and then stapled or stitched along the center fold, which forms the spine of the booklet.

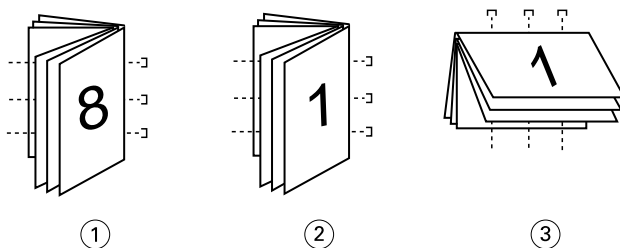

Callout Refers to

- 1 Saddle (left) binding
- 2 Saddle (right) binding
- 3 Saddle (top) binding

- **Nested saddle** - Combines saddle stitch and perfect binding methods. The signatures are folded together in groups. Each group forms a subset. The subsets are then stacked one on top of another and glued, as with perfect binding. When you specify nested saddle binding for a booklet in Fiery Impose, the sheets or subset setting allows you to specify the number of folded sheets in a group (subset). The cover is usually printed as a different job because it is printed with different paper stock and different imposition layout and sheet size.

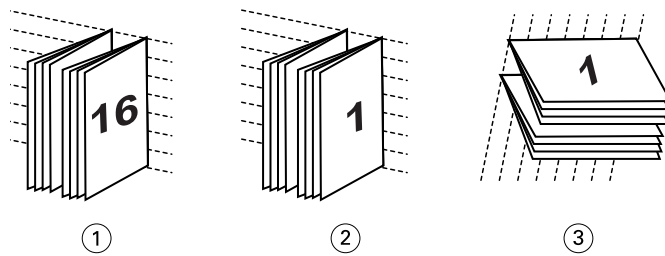

Callout Refers to

- 1 *Nested Saddle (left) binding*
- 2 *Nested Saddle (right) binding*
- 3 *Nested Saddle (top) binding*

- **Perfect binding** - Separate, folded pages are printed and stacked in booklet order. Finished pages are trimmed and then glued adjacent to one another. The cover is usually printed as a different job because it is printed with different paper stock and different imposition layout and sheet size.

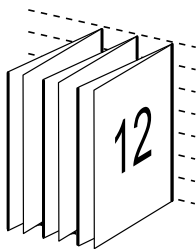

Creep

Creep is the shifting position of the page in a saddle-stitched bind. Creep moves the inside pages away from the spine.

All books and brochures use a sheet that is folded to create separate page areas. Because the sheet itself has some thickness, each fold causes a very small incremental shift in the location of the edge of each page relative to the others. The result is that the edges of pages furthest from the saddle's innermost fold seem to move away from the edges of pages closest to the innermost fold. As the number of pages in the saddle increases, so does the amount of this shift. To counteract the effects of this shift, the bindery trims the edges of the finished book to a common edge.

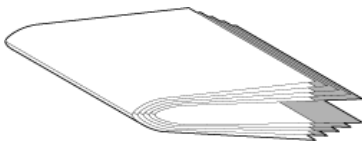

Trimming the bound pages resolves only part of the problem, however, as the edges of pages move, so do the content areas imaged on them. The apparent shift of content area caused by folding a sheet multiple times is known as creep or binder's creep. The effect of creep is that the content area of pages closer to the innermost fold in a saddle appear to move towards the outer margins of the page.

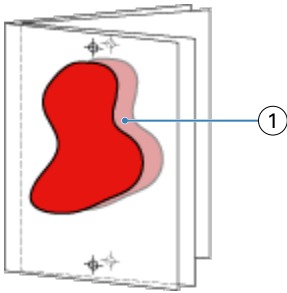

1 Creep

Creep becomes more noticeable as the number of sheets in a saddle increases, and its effect is most noticeable on pages farthest from the center fold of the saddle. Consequently, a book layout must also specify the number of sheets in each saddle because the number of sheets in each saddle affects the amount of creep that needs to be accounted for.

Adding blank pages to adjust layout

Fiery Impose and Fiery Compose allows you to add blank pages, and also inserts blank pages automatically where necessary for the imposition layout you select.

A book layout must adjust the placement of pages according to the total number of pages in the job. If the total page count is not an even multiple of the number of pages in the layout, one signature may be laid out, typically with blank pages, to accommodate the discrepancy.

The blank pages that are inserted automatically are called implicit blank pages. Because the implicit blank pages are not part of the original working document, you can choose to show the implicit blank pages or not.

- To show implicit blank pages, select **Show Implicit Blanks** from the **View** menu in Fiery Compose.

Depending on the **Row** and **Column** setting, as many as seven blank pages may be created. (For example, seven blank pages may be created for a 2X2 layout).

Preview a job for imposition

In the Command WorkStation **Preview** window, you can display sheet dimensions and navigate among the sheets of an imposed job.

When you select a job for imposition in Command WorkStation, the job opens in the **Preview** window. Jobs appear as thumbnails of the sheet in the **Sheet View** pane, either displaying the content or in wireframe view. If you select a page in **Page View**, it becomes selected in **Sheet View**.

For more information about previewing jobs in Command WorkStation, see *Fiery Command WorkStation Help*.

View and measure sheet dimensions

You can use the measurement tool to display basic sheet dimensions, to determine distance from a point of origin to a specific corner or edge of the page and sheet, and to change the point of origin (reference point).

- 1 Click the measurement tool icon.

- 2 Move the cursor around a page to make predefined Hot Spots appear.
Hot Spots are indicated by a horizontal or vertical line of red dashes.
- 3 Press the **Ctrl** key (on Windows) or the **Cmd** key (on macOS) and point and click to select a page.
The nine possible reference points for the page appear.
- 4 Point and click to select a desired reference point. When it is selected, the reference point appears as a red square.

View sheets of imposed jobs

You can view and navigate to the sheets of an imposed job by dragging or by sheet number.

- Do one of the following:
 - Drag with the drag tool to scroll across the sheets of the job.
 - Click the **Sheet** number display at the bottom of the **Sheet** view and then enter a sheet number in the text field.

Imposing a job

Fiery Impose allows you to choose from a predefined templates or create a custom template by changing the imposition settings and saving them. You can work in either wireframe view or thumbnail content view in the **Sheet View** pane.

To impose a job, open the job with Fiery Impose and apply a template.

You can also import your own templates or specify imposition settings. If you specify imposition settings, you first choose one of four workflows (product intents):

- **Compose** - For specifying settings in Fiery Compose before printing. This is for working with documents with paper sizes defined by the printer driver and source application. Allows you to build a job using Fiery Compose features.
- **Normal** - For 1-up imposition where clipping and printer's marks may be required.
- **Booklet** - For creating booklets of various types.
- **Gangup** - For creating various gangup pagination schemes.

Fiery server system pages are designed for administrative, informational purposes only. You cannot impose pages such as configuration, calibration, test pages, post-flight reports, and PANTONE books and charts.

Booklet Maker settings in Fiery Impose

You can use Fiery Impose to open a job with Booklet Maker settings, and then preview or modify the imposition layout. Fiery Impose translates and maps all Booklet Maker settings to Fiery Impose commands. See *Booklet Maker Help* in *Fiery Command WorkStation Help*.

Note: After you edit a job in Fiery Impose, you cannot edit it in Booklet Maker.

Imposition templates

Fiery Impose provides predefined templates. You can also create custom templates.

Imposition templates fall into three types: **Normal**, **Booklet**, and **Gangup**:

- Predefined **Normal** templates include **Default Template** and **1-up full bleed**.
- Predefined **Booklet** templates include **2-up perfect**, **2-up saddle**, and **4-up head to head**.
- Predefined **Gangup** templates include **3-up trifold brochure**, **4-up gate fold**, and **4-up z fold**.

Note: The default predefined imposition templates use the **Based on Crop Box** finish size setting.

Note: **Normal**, **Booklet**, and **Gangup** templates list factory templates at the top followed by custom templates. Both factory templates and custom templates are sorted in alphanumeric ascending order.

One way to create a custom template is by changing the settings in a predefined template. Select the template, make changes, and save the template with a new name. The new settings are applied immediately. You must have a Fiery Impose license to save a template.

In the **Preferences** window, you can set a path to the folder or directory where you want to store custom templates. This setting is in the **Impose** tab, under **Imposition Template Path**.

Imposition templates can also be edited from Fiery Hot Folders, Job Properties, Virtual Printers, and Presets, if you have a Fiery Impose license.

Note: The **User Defined** and **Based on Trim Box** finish size workflows require PDF source files. PostScript files and VDP formats other than PDF/VT are not supported.

Support for User Defined and Based on Trim Box finish size templates

Custom imposition templates can be created with **User Defined** and **Based on Trim Box** finish size settings.

The templates can be used in any job submission method or workflows including Fiery Impose, Fiery Hot Folders, a Fiery server running Fiery system software FS200 Pro or later, or a client computer connected to a Fiery server running Fiery system software FS200 Pro or later (through Virtual Printers, Job Properties, and Server Presets).

Note: Integrated Fiery servers running Fiery system software FS200 do not support the **User Defined** or **Based on Trim Box** finish size for custom imposition templates.

The Fiery Impose license must be activated on the client computer or at the Fiery FS200 Pro (Windows-based) server when setting up a workflow. The following table explains where the Fiery Impose license needs to be activated for **User Defined** and **Based on Trim Box** finish size workflows:

Table 1: License Activation for templates with User Defined and Based on Trim Box finish size

Fiery System Software	License Activation		Supported Workflow			
	Server License	Client License	Job Properties	Server Presets	Virtual Printers	Hot Folders
FS200 Pro (windows-based) or later	Yes	Yes	Supported (1,3)	Supported (3)	Supported (2)	Supported (3)
	Yes	No	Supported (1)	Supported	Supported	Not Supported
	No	Yes	Not Supported	Not Supported	Not Supported	Supported (3)
	No	No	Not Supported	Not Supported	Not Supported	Not Supported
FS200, FS150 Pro and earlier	Yes	Yes	Not Supported	Not Supported	Not Supported	Supported (3)
	Yes	No	Not Supported	Not Supported	Not Supported	Not Supported
	No	Yes	Not Supported	Not Supported	Not Supported	Supported (3)
	No	No	Not Supported	Not Supported	Not Supported	Not Supported
			<p>(1) When the User Defined finish size template is created on the Fiery server then a Server Preset must be created in order to have access from Job Properties.</p> <p>(2) Virtual Printer workflow is only available if the User Defined finish size template is created on the Fiery server.</p> <p>(3) When Job Properties, Server Presets, or Hot Folders workflows based on User Defined finish size are set up on a client computer, the workflows can only be accessed on that client computer.</p>			

The following table explains where the Fiery Impose license needs to be activated for **Crop Box** finish size workflows:

Table 2: License Activation for templates with Crop Box finish size

Fiery System Software	License Activation		Supported Workflow			
	Server License	Client License	Job Properties	Server Presets	Virtual Printers	Hot Folders
FS200 Pro (windows-based) or later	Yes	Yes	Supported	Supported	Supported	Supported (4)
	Yes	No	Supported	Supported	Supported	Not Supported
	No	Yes	Supported (4)	Supported	Not Supported	Supported (4)
	No	No	Not Supported	Not Supported	Not Supported	Not Supported
FS200, FS150 Pro and earlier	Yes	Yes	Supported	Supported	Supported	Supported (4)
	Yes	No	Supported	Supported	Supported	Not Supported
	No	Yes	Supported (4)	Supported (4)	Not Supported	Supported (4)
	No	No	Not Supported	Not Supported	Not Supported	Not Supported
			(4) When Job Properties , Server Presets , or Hot Folders workflows based on Crop Box finish size are set up on a client computer, the workflows can only be accessed on that client.			

Apply an Imposition template

You apply a custom template the same way as a predefined template.

- 1 Click the **Template** menu at the top of the **Settings** pane.
- 2 Select the name of the template you want to use in the **Template Browser**.

The new settings are applied immediately when you select a template.

Save a custom Imposition template

You can save a custom template if you have a licensed version of Fiery Impose.

- 1 Create a custom template.
- 2 Click the **Save** icon.
- 3 Type a name for the template in the **Save Template** window.

Delete a custom template

You can delete a custom template.

- 1 Select the template you want to delete from the **Template** menu.
- 2 Click the **Delete Template** icon.

Note: A job will continue to use the deleted template settings until you select another template or specify new imposition settings.

Save an imposed job

You can save an imposed job as a regular imposed job or flattened PDF on the Fiery server or local disk.

Saving a job as a flattened PDF allows you to print the job or file on different printers that may not have a processor imposition capability. The flattened PDF can easily be sent to customers for remote signature level proofing.

For more information, see [Set trim marks](#) on page 59.

Note: Fiery Impose cannot save a VDP imposition job in Adobe PDF format.

Save a job as a regular imposed job

When you save as a regular imposed job, you save the job to the Fiery server with extension .dbp with the job ticket. You can then reopen the job and make changes.

- 1 Select **File > Save**.
- 2 Choose a location to save the file in the **Where** menu.
- 3 Clear the **Flattened** check box.

Save a job as a flattened PDF

When you save a job as a flattened PDF, you can save back to the Fiery server or local disk and archive the imposed PDF for future reprinting.

Note: When you save as a flattened PDF, you might want to give the job a new file name to avoid overwriting your original PDF file.

In Fiery Impose, a flattened PDF does not include tab and blank sheet pages, but does include implicit blank pages. When you save a job, the save window remembers where you saved it and whether you saved it as a flattened PDF and uses these options the next time you save a job.

- 1 Select **File > Save**.
- 2 Type a filename in the **Save as** field.
- 3 Choose a location to save the file in the **Where** menu.
- 4 (Optional) Click **Settings**.
- 5 (Optional) Set any of the following in the **PDF Output Settings** window and then click **OK**:

Under **Rotation**:

- **Front** - Select **90 degrees Clockwise**, **180 degrees**, or **90 degrees Counter-Clockwise** to rotate the front pages of the PDF output. Selecting **None** will not apply rotation.
- **Back** - Select **90 degrees Clockwise**, **180 degrees**, or **90 degrees Counter-Clockwise** to rotate the back pages of the PDF output. Selecting **None** will not apply rotation.

Under **Security**:

- **Method** - Select **Password protected Editing** or **Password protected Printing and Editing** to enable the **Password** and **Confirm** fields. Selecting **None** will not apply security features.
- **Password** - Type your desired password.
- **Confirm** - Type the same password from the **Password** field.

- 6 Click **OK**.

Imposition template reference

Fiery Impose provides predefined templates. The settings that a template covers depend on the specific template.

1-up full bleed template

The **1-up full bleed** layout prints one page per sheet. Marks indicates where to cut the paper so that the color content extends to the edge of the paper. The following settings apply for this layout:

- Under **Bleed**, **Apply Both** is selected.
- In the **Marks** window:
 - **Trim** tab - Black, Solid 1/2 pt. wide, 0.2222 inch long Standard style marks
 - **Fold** - Black, Dotted 1/2 pt. wide, 0.2222 inch long marks
 - **Job Label** - Horizontal, Name, Sheet Info, and Date & Time in the upper-left corner
- **Scale to fit** is selected for the **Scaling** option.
- **Normal** is selected as the template setting.

The **1-up full bleed** layout does not have page number restrictions.

2-up perfect template

The **2-up perfect** template creates signatures for a perfect-bound book, with each sheet folded once and stacked on top of one another. The following settings apply for this layout:

- **Top-top** is selected for the **Duplex** option.
- Under **Bleed**, **Apply Both** is selected.
- In the **Marks** window:
 - **Trim** tab - Black, Solid 1/2 pt. wide, 0.2222 inch long Standard style marks
 - **Fold** tab - Black, Dotted 1/2 pt. wide, 0.2222 inch long marks
 - **Job Label** tab - Horizontal, Name, Sheet Info, and Date & Time in the upper-left corner
- **Scale to fit** is selected for the **Scaling** option.
- **Booklet** is selected as the template setting.
- **Perfect** and **Left** are selected as the **Booklet** settings.

The **2-Up perfect** layout is for jobs that have multiples of four pages, but you can use it with jobs that have any number of pages. Fiery Impose adds additional blank pages as necessary. Pages are ordered in groups of four so that, when folded, each sheet has four sequential pages.

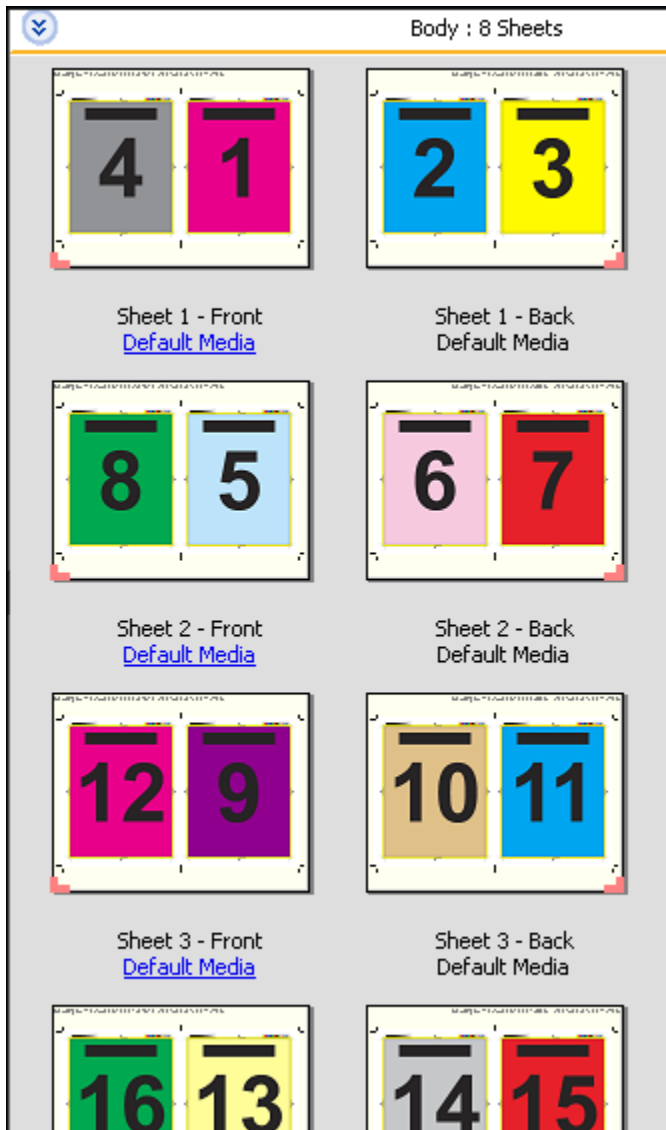

Note: The **Creep** adjustment is not available in this template.

2-up saddle template

The **2-up saddle** layout creates sheets for a saddle bound book. All of the sheets are folded together, one inside the other. The following settings apply for this layout:

- **Top-top** is selected for the **Duplex** option.
- Under **Bleed**, **Apply Both** is selected.
- In the **Marks** window:
 - **Trim** tab - Black, Solid 1/2 pt. wide, 0.2222 inch long Standard style marks
 - **Fold** tab - Black, Dotted 1/2 pt. wide, 0.2222 inch long marks
 - **Job Label** tab - Horizontal, Name, Sheet Info, and Date & Time in the upper-left corner
- **Scale to fit** is selected for the **Scaling** option.

- **Booklet** is selected as the template setting.
- **Saddle** and **Left** are selected as the **Booklet** settings.

The **2-up saddle** layout is for jobs that have multiples of four pages, but it can be used with jobs that have any number of pages. Fiery Impose adds additional blank pages as necessary. Pages are ordered so that, when sheets are folded and stitched together, the pages are sequential.

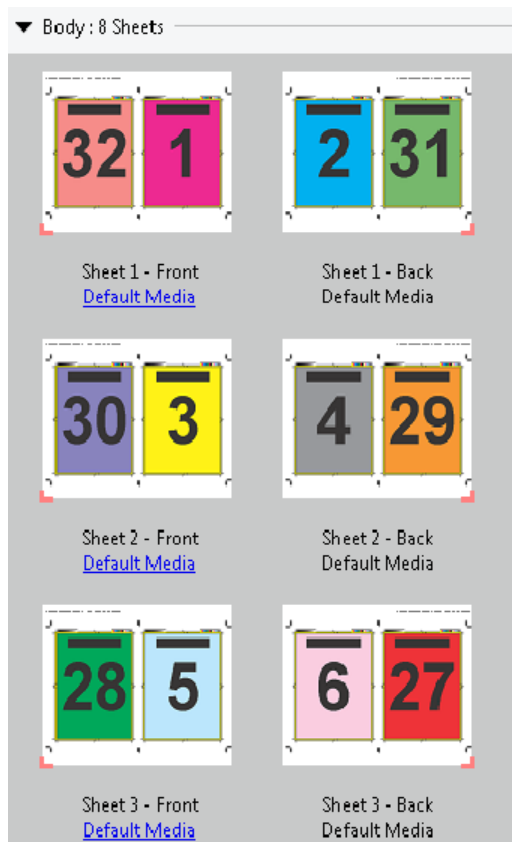

3-up trifold brochure template

The **3-up trifold brochure** layout consists of a single sheet folded into three sections. Although the three sections are the same width, the space between each section varies so that the leftmost panel can be folded over the other two panels. The following settings apply for this layout:

- **On** is selected for the **Duplex** option.
- In the **Marks** window:
 - **Trim** tab - Gray, Solid 1/2 pt. wide, 0.2222 inch long Standard style marks
 - **Job Label** tab - Horizontal, Name, Sheet Info, and Date & Time in the upper-left corner
- **Scale to fit** is selected for the **Scaling** option.
- **Gangup** is selected as the template setting.
- **Unique** and **Left/Right** are selected as the **Gangup** settings.

The **3-up trifold brochure** layout is for jobs that have six pages or multiples of six pages, but you can use it with jobs that have any number of pages. Fiery Impose adds additional blank pages as necessary.

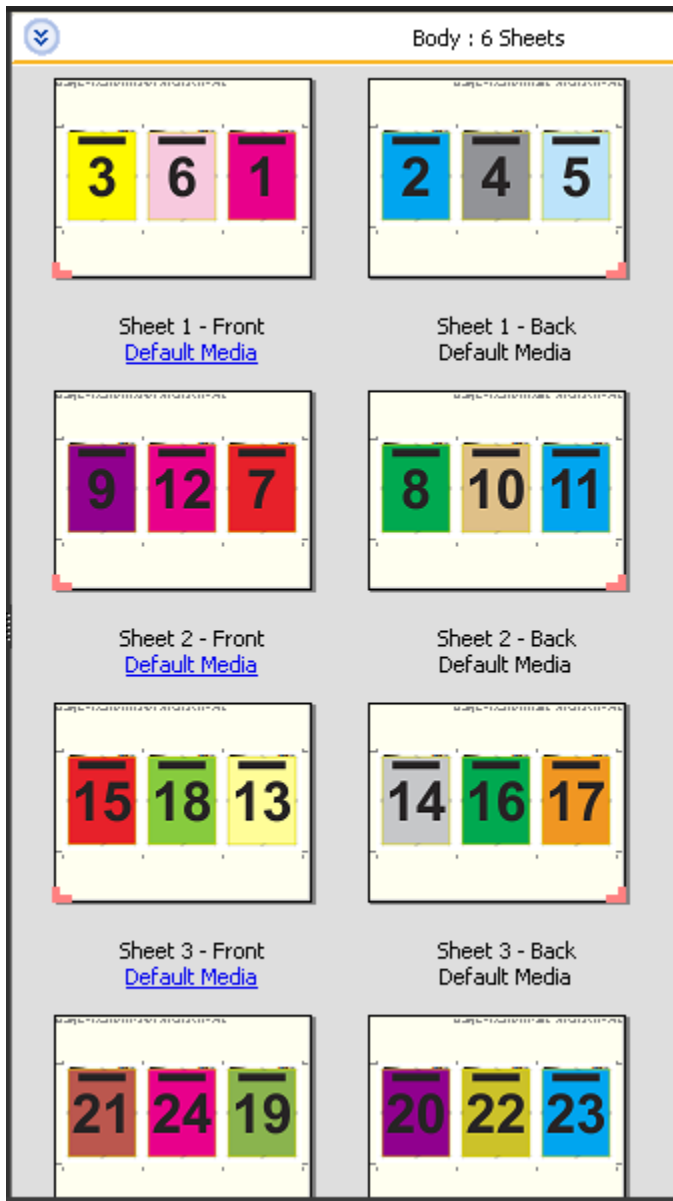

The **3-up trifold brochure** is usually folded as shown in the following illustration.



4-up gate fold template

The **4-up gate fold** layout is used most often for a four-panel brochure. The finished brochure unfolds to double, then four times the original size. The following settings apply for this layout:

- **On** is selected for the **Duplex** option.
- Under **Bleed**, **Apply Both** is selected.
- In the **Marks** window:
 - **Trim** tab - Gray, Solid 1/2 pt. wide, 0.2222 inch long Standard style marks
 - **Job Label** tab - Horizontal, Name, Sheet Info, and Date & Time in the upper-left corner
- **Scale to fit** is selected for the **Scaling** option.
- **Gangup** is selected as the template setting.
- **Unique** and **Left/Right** are selected as the **Gangup** settings.

The **4-up gate fold** layout is for jobs that have multiples of eight pages, but you can use it with jobs that have any number of pages. Fiery Impose adds additional blank pages as necessary.

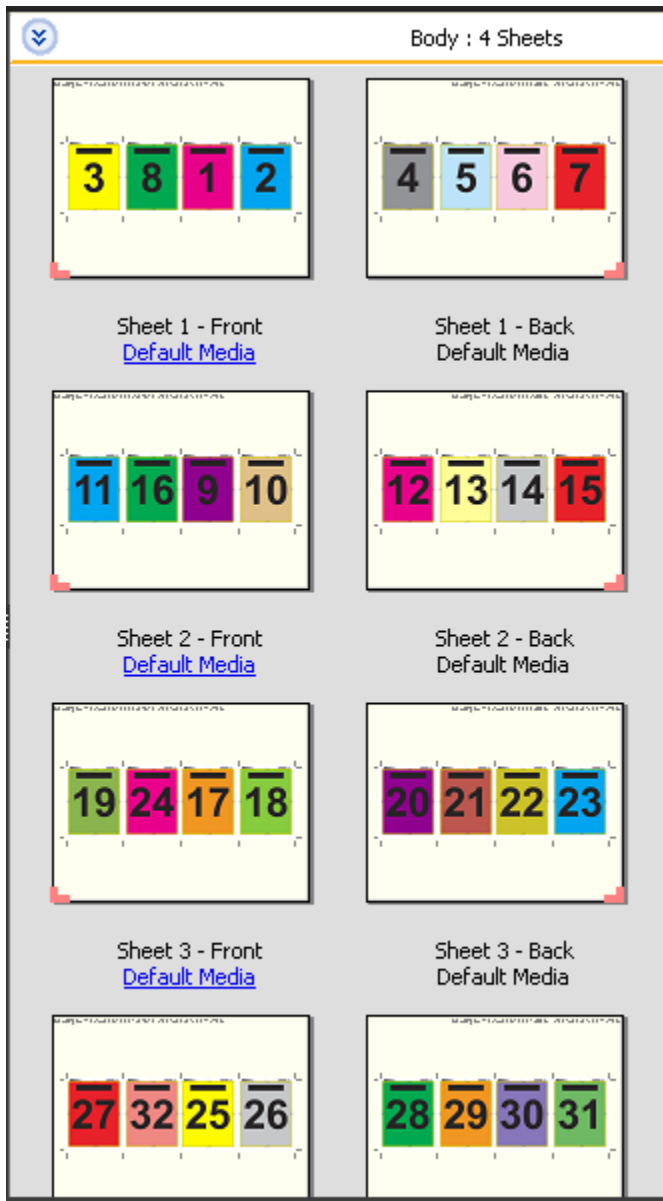

The **4-up gate fold** is usually folded as shown in the following illustration.

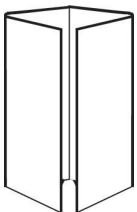

4-up head to head template

The **4-up head to head** layout is for booklets created from a layout of four pages on each side of the printed sheet. Rotating the two topmost pages lets you fold the signature both horizontally and vertically, and trimmed. The finished booklet has all pages in the correct order and rotation.

The following settings apply for this layout:

- **Top-top** is selected for the **Duplex** option.
- Under **Bleed**, **Apply Both** is selected.
- **Gutter** is defined.
- In the **Marks** window:
 - **Trim** tab - Black, Solid 1/2 pt. wide, 0.2222 inch long Standard style marks
 - **Fold** tab - Black, Dotted 1/2 pt. wide, 0.2222 inch long marks
 - **Job Label** tab - Horizontal, Name, Sheet Info, and Date & Time in the upper-left corner
- **Scale to fit** is selected for the **Scaling** option.
- **Booklet** is selected as the template setting.
- **Saddle** and **Left** are selected as the **Booklet** settings.

The **4-up head to head** layout is for jobs that have multiples of eight pages, but you can use it for jobs that have any number of pages. Fiery Impose adds additional blank pages as necessary. Pages are ordered so that, when sheets are folded with two folds at 90 degrees, trimmed, and stitched together into signatures, the pages are sequential.

Note: Although this layout requires two folds, the template applies a fold mark on the spine fold only. For example:

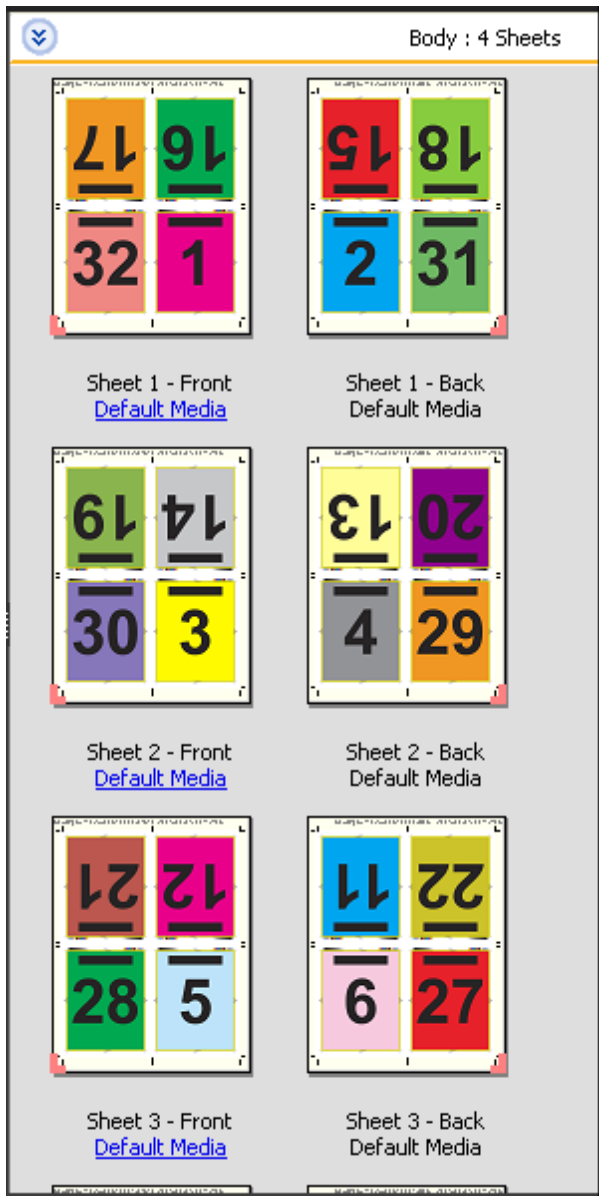

The **4-up head to head** is usually folded as shown in the following illustration. If you are folding more than one sheet, you must stack all the sheets and fold them together.

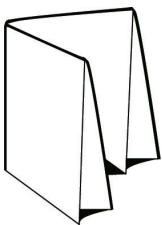

4-up z-fold template

The **4-up z-fold** layout lets you fold many panels on top of one another without stressing the folded spine. A common example is a road map. The following settings apply for this layout:

- **On** is selected for the **Duplex** option.
- In the **Marks** window:
 - **Trim** tab - Gray, Solid 1/2 pt. wide, 0.2222 inch long Standard style marks
 - **Job Label** tab - Horizontal, Name, Sheet Info, and Date & Time in the upper-left corner
- **Scale to fit** is selected for the **Scaling** option.: **Scale to fit**
- **Gangup** is selected selected as the template setting.
- **Unique** and **Left/Right** are selected as the **Gangup** settings.

The **4-up z-fold** layout is for jobs that have eight pages, but you can use it with jobs that have any number of pages. Fiery Impose adds additional blank pages as necessary.

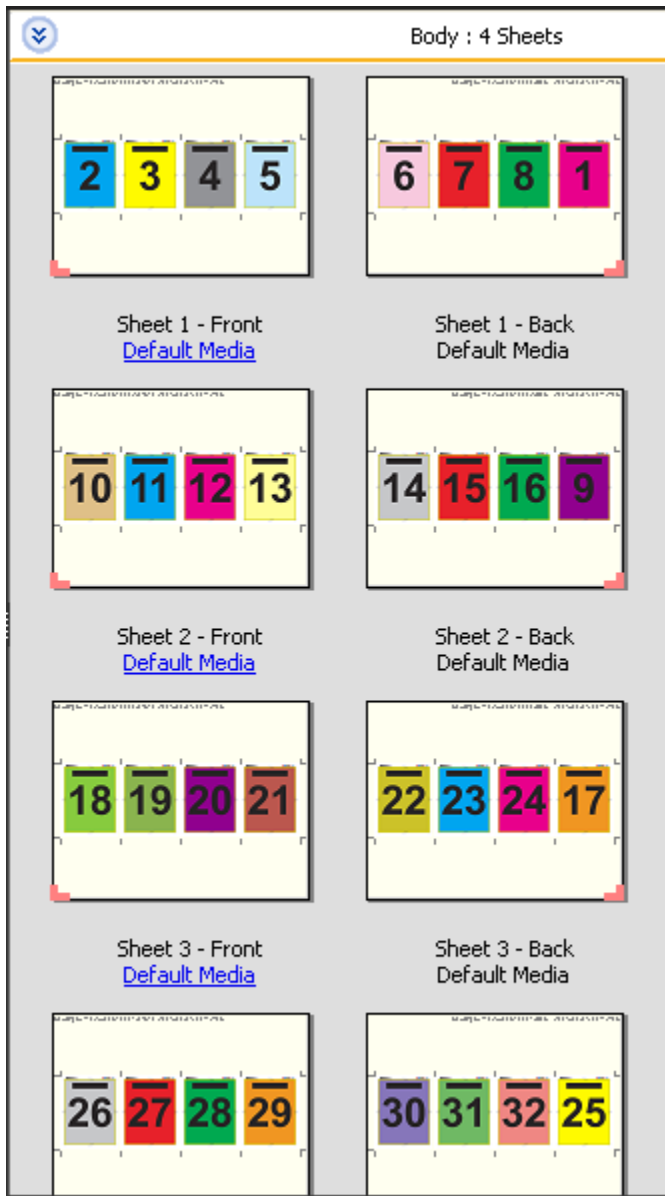

The **4-up z-fold** is usually folded as shown in the following illustration.



Gangup printing in Fiery Impose

Fiery Impose provides **Gangup Repeat**, **Gangup Unique**, and **Unique-Collate Cut** imposition.

Fiery Impose also offers **Duplo - Long Edge Feed** and **Duplo - Short Edge Feed** for imposition jobs being finished on a Duplo offline finisher with bindery features such as folding, slitting, cutting, and creasing.

Gangup Repeat

The **Repeat** option enables step-and-repeat printing. Step-and-repeat is most often used when printing multiple copies of a single document.

The **Best Fit for Gangup Repeat** function automatically lays out the content on the sheet for optimal use of the sheet size, using a **Gangup Repeat** workflow. To use this feature, select the **Best Fit for Gangup Repeat** icon. For information, see [Best Fit for Gangup Repeat](#) on page 44.

Gangup Unique

The **Unique** option places pages in an arrangement that is often more appropriate for printing a single copy of a job. This option does not fully collate itself (hand collating is necessary), but optimizes the sheet size while limiting the run to a single copy.

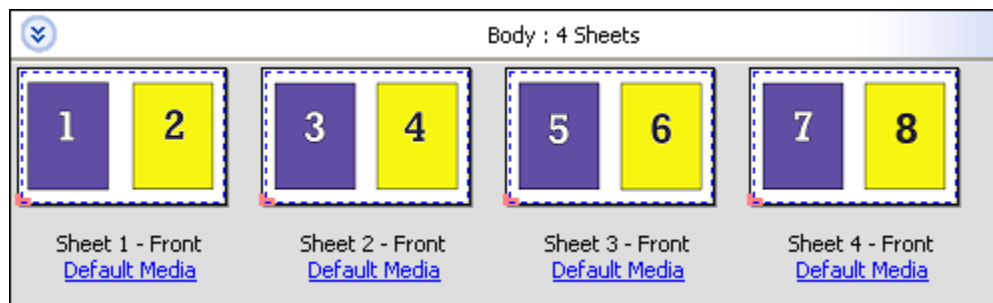

Unique-Collate Cut

Unique-Collate Cut places pages in an arrangement that allows the pages to fall into the correct order when the sheets are stacked and cut. This option minimizes the need for collating by hand and is most appropriate for printing single copies of a document.

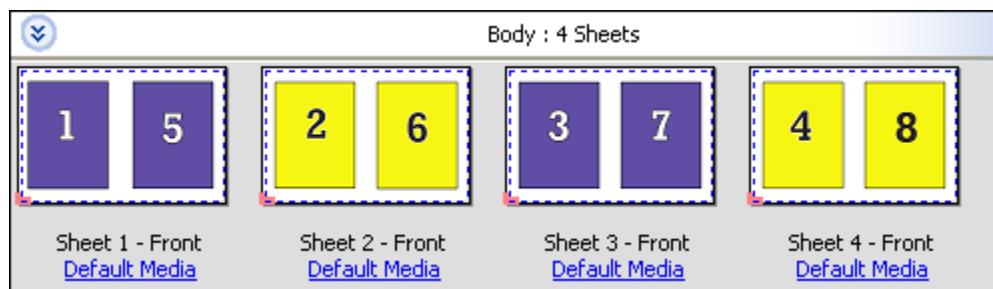

Duplo - Short Edge Feed

Duplo - Short Edge Feed sets a pagination direction that enables feeding the final printed sheet into a Duplo finisher at the sheet's short edge. The columns or rows are perpendicular to the shortest sheet edge.

VDP and non-VDP PDF and PostScript jobs can use Duplo finishing. You can automatically configure Duplo offline finishers by reading a simple barcode printed on the sheets. The finisher reads a registration mark on the sheet and

positions the sheet in relation to the mark as the sheet feeds through the machine. When specifying Duplo for a gangup imposition layout, you can specify the registration and barcode in the **Marks** window.

Duplo - Long Edge Feed

Setting **Duplo - Long Edge Feed** for a gangup imposition layout creates a pagination direction that enables the final printed sheet to be fed into a Duplo finisher at the sheet's long edge. The columns or rows are arranged in a direction perpendicular to the longest sheet edge.

You can use Duplo finishing for VDP and non-VDP PDF and PostScript jobs. Reading a simple barcode printed on the sheets automatically configures Duplo offline finishers. The finisher compensates for stack drift and image shift by reading a registration mark printed on the sheet and positioning the sheet in relation to the mark as the sheet feeds through the machine.

When specifying Duplo for a gangup imposition layout, you can specify the registration and barcode in the **Marks** window.

Gangup with top finished edge

Gangup with top finished edge allows you to automatically rotate the individual slots or pages on the back surface of a sheet 180 degrees for top-edge binding of a duplex job.

Gangup with top finished edge (slot rotation) works with the existing layout styles in Fiery Impose. You can set up slot rotation templates which can then be used for Fiery Hot Folders and Virtual Printers.

Gangup with top finished edge is available for the following gangup styles:

- Repeat
- Unique-Collate Cut
- Duplo - Short Edge Feed
- Duplo - Long Edge Feed

The following table shows the settings required for gangup with top finished edge.

Gangup style	Duplex	Layout style	Slot rotation
Repeat	On	Any of the styles:	Yes
Unique-Collate Cut	On	• Standard	Yes
Duplo - Short Edge Feed	On	• Head to head	Yes
Duplo - Long Edge Feed	On	• Foot to foot	Yes
		• Reversal	
		• Reversal Alternate	

Create a gangup job with top finished edge

- 1 Import your job into the Held list in Command WorkStation.

- 2 Select the job and select **Impose** from the **Actions** menu, or the right-click menu.
- 3 Select **Gangup** in the **Settings** pane in the **Fiery Impose** window, and one of the following styles:
 - **Repeat**
 - **Unique-Collate Cut**
 - **Duplo - Short Edge Feed**
 - **Duplo - Long Edge Feed**
- 4 Specify settings as outlined below:
 - Select **Top** for the finishing edge.
 - Select **On** for the **Duplex** option.
 - Select **Any** for the **Layout Style** option.

Note: The settings above are required. You can specify other settings as required.

The result of your choices are displayed in the **Sheet View** pane.

Dynamic trim box automation

Dynamic trim box automation is an automatic media-size-based imposition for gangup layouts.

After creating a gangup layout, you can save it as a template and use it to lay out other jobs automatically. You need only one such template per sheet size. When a gangup job comes in, you can drag the new job onto a hot folder based on the sheet size template. Fiery Impose automatically determines the best layout (N-up and orientation) for the job to print the maximum number of items per sheet.

This automated workflow, which uses the **Based on Trim Box** finish size, dynamically creates the layout for different small items (such as business cards, postcards, or concert tickets) on a larger-sized sheet (such as 11x17). This workflow applies only to gangup jobs.

Note: You can use custom imposition templates created with the **Based on Trim Box** workflow, or with the user defined workflow, with Fiery Hot Folders, Virtual Printers, Presets, and Command WorkStation Job Properties. For information about supported workflows, required software licenses, and the version of Fiery system software needed on the Fiery server you are connected to, see [Support for User Defined and Based on Trim Box finish size templates](#) on page 26.

Automate gangup imposition with Fiery Hot Folders

You can automate the setup of gangup imposition (for example, for business cards or postcards) to print on the same sheet size, and streamline the setup and production using a single hot folder for these products regardless of their finish size.

When you use this sheet size again for different products, you can drag the new job onto a hot folder based on the template you created. Fiery Impose automatically creates a best-fit layout for the new job.

- 1 In the Fiery Impose **Settings** pane, create a gangup layout by selecting **Gangup**, and set the **Finish Size** to **Based on Trim Box**.
- 2 (Optional) Click **Define** for the **Gutter** option to specify settings for gutters.

- 3 (Optional) Click **Define** for the **Marks** option to specify trim marks.
- 4 Click the save icon at the top of the **Settings** pane.
- 5 Type a name for the template and save as a regular imposed job.
- 6 Open Fiery Hot Folders.
- 7 Click **New** to create a new hot folder.
- 8 Type a name for the hot folder in the **Hot Folder Settings** window.
- 9 Click **Select** and then click **Connect** to connect to a Fiery server.
- 10 Select **Define** for the **Job Properties** option.
- 11 In the **Job Properties** window, select **Layout > Impose**.
- 12 Select the template that you created for the **Templates** option.
- 13 Click **OK**.
- 14 In the **Hot Folder Settings** window, select a desired action for the **Job action** option.
- 15 Click **OK**.

The hot folder is created on the desktop.
- 16 On the desktop, drag a new job with small products to the hot folder.
- 17 Go to the Fiery server. The job should appear there and be processed.

Fiery Impose automatically determines the best layout to print the maximum number of items.

Best Fit for Gangup Repeat

Best Fit for Gangup Repeat automatically lays out the content on the sheet for optimal use of the sheet size, using a Gangup and Repeat workflow.

Fiery Impose calculates how many sheets of the media are needed for the number of finished products required. **Best Fit for Gangup Repeat** is ideal for business cards or any job where the printer produces a large quantity of repeatable content. The layout is calculated using either the **Based on Crop Box** finish size or **User Defined** finish size, whatever the setting is for **Finish Size** in the **Settings** pane.

Using Best Fit for Gangup Repeat with Fiery Hot Folders and Job Properties

To use **Best Fit for Gangup Repeat** when editing Fiery Impose templates from Fiery Hot Folders, you must first:

- Specify the sheet size.
- Set the finish size for imposed jobs to **User Defined** or **Based on Crop Box**.

These prerequisites also apply when you edit Fiery Impose templates from **Job Properties**.

Specify Best Fit for Gangup Repeat

You can select the **Best Fit for Gangup Repeat** option for automatic layout of your gangup and repeat job.

The imported job must be one that is suitable for a gangup and repeat layout, for example, a business card.



1 Select a job in the **Held** list in Command WorkStation and open Fiery Impose in one of the following ways:

- Select **Impose** from the **Actions** menu.
- Right-click the job and select **Impose**.

2 In the **Fiery Impose** window, select **Best Fit for Gangup Repeat** from the **Actions** menu.

You can also click the **Best Fit for Gangup Repeat** icon in the **Settings** pane when **Gangup Repeat** is selected as the product intent workflow.

3 Set the following:

Option	Description
Number of finished products	Automatically populates as 100, but can be set to more or less. Note: The maximum number of finished products cannot result in a copy count which exceeds 9999. In this case the copy count will show as "Invalid". To correct this, change one of the values until the copy count is less than 10,000.
Sheet	Select from the menu of supported media.
Layout orientation	Automatic, Portrait, or Landscape.
Margin	Allows control of the space outside the layout for other uses than the layout. To enable margins, click the toggle button to display the green check mark. To disable margins, click the toggle button to display the red "X". Margin enabled:  Margin disabled:  <ul style="list-style-type: none"> • Disabled - Populated with the non-printable margins from the printer driver. • Enabled-Zero - Entering zero produces the same behavior as the Use Non-printable area check box in the Settings pane. • Enabled-Custom - Type a custom margin.
Gutter	Type parameters for the space between adjacent products in the layout, both horizontally and vertically. Note the difference between gutter and the margin, which is the space around the layout.
Spoilage	Specify the number of additional sheets that need to be produced to account for clamp marks from equipment, dirt on bottom sheets, or other reasons that may cause spoilage.
Copies	The number of copies of the job which are necessary to produce the quantity of finished products. This value is for information only and cannot be overridden.

Option	Description
Overage	<p>Note: This does not necessarily reflect the number of sheets, because the original document may consist of multiple items, for example, two distinct business cards.</p> <p>The number of finished products that are produced above the required number. Overage occurs when the required number of finished products does not fill an entire sheet. Fiery Impose will always fill the sheet, thus creating overage.</p>

You can override the settings and make changes in the **Settings** pane after closing the **Best Fit for Gangup Repeat** window, but doing so may result in more or less finished products being printed, unless you manually adjust the copy count in the **Copies** option in **Settings**. If you want auto calculation of the layout, you must open the **Best Fit for Gangup Repeat** window again.

Specify Gangup settings in Fiery Impose

You can specify gangup styles, page order, gutter size, and gangup method.

Make sure that the gangup style and method can be used together. For details about which you can combine, see [Combining gangup styles with gangup methods](#) on page 48.

Set gangup style





You can set a gangup style.

- 1 Select **Gangup** in the **Template** menu.
- 2 Select one of the following in the template style menu:
 - **Unique**
 - **Repeat**
 - **Unique-Collate Cut**
 - **Duplo - Short Edge Feed**
 - **Duplo - Long Edge Feed**

Set Page Order

The **Page Order** options allow you to specify the flow direction of pagination within the layout.

Note: The **Page Order** options are available only for the **Unique** gangup style.

- Click one of the following in the **Page Order** section of the **Settings** pane:
 -  - Orders pages from left to right horizontally, by row, starting with the top row.
 -  - Orders pages from right to left horizontally, by row, starting with the top row.
 -  - Orders pages from top to bottom vertically, by column, starting with the furthest left column.
 -  - Orders pages from top to bottom vertically, by column, starting the furthest right column.

Set Gutters

You can set gutters for gangup jobs. Gutters are extra margins that allow space for binding or other finishing options. Fiery Impose defines the locations of gutters for you according to the layout and sheet size governing the imposition of the job. For example, perfect-bound jobs typically require larger gutters than saddle-stitched jobs to provide room for grinding off the spines and gluing signatures together when the book is bound.

- 1 Click **Define** for the **Gutter** option.
- 2 In the **Gutter** window, set the gutter measurement by typing in the available text fields for each gutter in your layout.
- 3 (Optional) Click **Apply All** to apply the same measurement to all gutters.
- 4 (Optional) Select the **"Scale to fit" uses gutter settings** check box to control the placement of the page content.. If you selected **Scale to fit** before setting gutters in the **Gutter** dialog box, use the **"Scale to fit" uses gutter settings** check box to control the placement of the page content.

The **"Scale to fit" uses gutter settings** check box is available when you select **Scale to fit** for the Scale option in the Fiery Impose **Settings** pane before opening the **Gutter** window.

- Not selecting the check box (default setting) - **Scale to fit** does not include the gutter size in the calculation. Changing the gutter size does not scale the page content, and instead shifts the content.
- Selecting the check box - **Scale to fit** includes the gutter size in the calculation. Changing the gutter size scales the page content to fit within the area defined by the rows and columns and gutter settings.

Scale to fit options with gutters

Fiery Impose offers two different **Scale to fit** behaviors with gutters.

Scale to fit is needed when the original page does not fit entirely within the available imposition slot on the sheet. The imposition slot size is defined by the sheet size and the number of imposition slots on the page which is a function of the number of rows and columns. The gutter setting defines the space between the imposition slots.

When you select **Scale to fit**, the **Gutter** window offers a **"Scale to fit" uses gutter settings** check box. The behavior of the check box is as follows:

- Not selecting the check box (default setting) - **Scale to fit** does not include the gutter size in the calculation. Changing the gutter size does not scale the page content, and instead shifts the content.
- Selecting the check box - **Scale to fit** includes the gutter size in the calculation. Changing the gutter size scales the page content to fit within the area defined by the rows and columns and gutter settings.

Note: The selected "**Scale to fit**" **uses gutter settings** selection cannot be saved for Fiery Impose templates. If you do select the check box and save the settings as a Fiery Impose template, the check box selection is cleared.

When you select **Scale to fit**, changing the gutter size changes the scaling automatically. The document is resized so it continues to fit in the available area.

Note the following:

- The **Scale to Fit** setting always fits the page within the available imposition slot, regardless of the gutter or sheet size.
- Changing rows and columns or sheet size affects the scaled size. Changing the gutter size affects the scaled size. The **Scale to fit** setting scales down, not up.

Set gangup methods in Fiery Impose

You can choose a gangup method in Fiery Impose. Depending on the gangup style, some sgangup methods may not be available.

- Select one of the following gangup methods in the **Layout Style** list:
 - **Standard**
 - **Head to head**
 - **Foot to foot**
 - **Reversal**
 - **Reversal Alternate**

Combining gangup styles with gangup methods

Which gangup styles and methods you can use together depends on whether the job format is PostScript, PDF, or VDP.

The following table shows which gangup styles and methods you can use together for normal jobs in PostScript or PDF format.

Gangup styles	Standard	Head to Head	Foot to Foot	Reversal	Reversal Alternate
Repeat	Yes	Yes	Yes	Yes	Yes
Unique	Yes	Yes	Yes	Yes	Yes
Unique-Collate Cut	Yes	Yes	Yes	Yes	Yes

The following table shows which gangup styles and methods you can use together for VDP jobs.

Gangup styles	Standard	Head to Head	Foot to Foot	Reversal	Reversal Alternate
Repeat	Yes	No	No	No	No
Unique	Yes	Yes	Yes	Yes	Yes
Unique-Collate Cut	Yes	Yes	Yes	Yes	Yes
Multi-Record Collate	Yes	Yes	Yes	Yes	Yes
Cut and Stack	Yes	Yes	Yes	Yes	Yes
Duplo - Short Edge Feed	Yes	No	No	No	No
Duplo - Long Edge Feed	Yes	No	No	No	No

Standard style is the only layout style supported for variable data printing gangup repeat jobs. All layout styles are supported for non-variable data printing jobs in PostScript or PDF format submitted to Command WorkStation through the Import function or printer driver. For jobs submitted through Hot Folders, Fiery Impose cannot distinguish between variable data printing and non-variable data printing jobs, so **Standard** is the only **Gangup** repeat style supported for variable data printing and non-variable data printing jobs.

Specify Layout Row & Column settings for Gangup

You can specify the number of rows and columns for Gangup.

- Do one of the following to specify rows and columns for the **Layout Row & Column** option:
 - Click the arrow buttons up or down to choose a value in the field.
 - Type the desired value in each field

Note: You can add up to 25 rows and columns.

Specify Repeat Booklet finish feature

The **Repeat Booklet** allows step-and-repeat printing of two identical booklets on one sheet for offline finishing, not inline finishing. **Repeat Booklet** requires a layout of two rows by two columns.

- 1 Select **Booklet** for the product intent.
- 2 Select **2 X 2 Repeat Booklet** in the **Layout Row & Column** option.

Gangup imposition methods for VDP jobs

For Variable Data Printing (VDP) jobs, you can use single-record or multiple-record imposition methods.

- **Single-Record Imposition** can use **Gangup repeat**, **Gangup unique**, or **Unique-Collate Cut**. See [Gangup printing in Fiery Impose](#) on page 41.
- **Multiple Record Imposition** can use **Multi-Record Collate**, **Cut and Stack**, or **Stack size**.

Multi-Record Collate

Multi-Record Collate places pages from different records sequentially on the sheet surface. The first page from each record is placed on the sheet surface until all the records are exhausted. Then a new sheet is started, and the second page from each record is placed until all the records are exhausted. The process is repeated until all the pages are placed.

The following preview shows a 2-by-2, simplex, **Multi-Record Collate** layout applied to a VDP job that contains four records. The records consist of four pages each. "R" stands for Record, and "P" for Page. For example, "R1 P1" is Page 1 for Record 1.

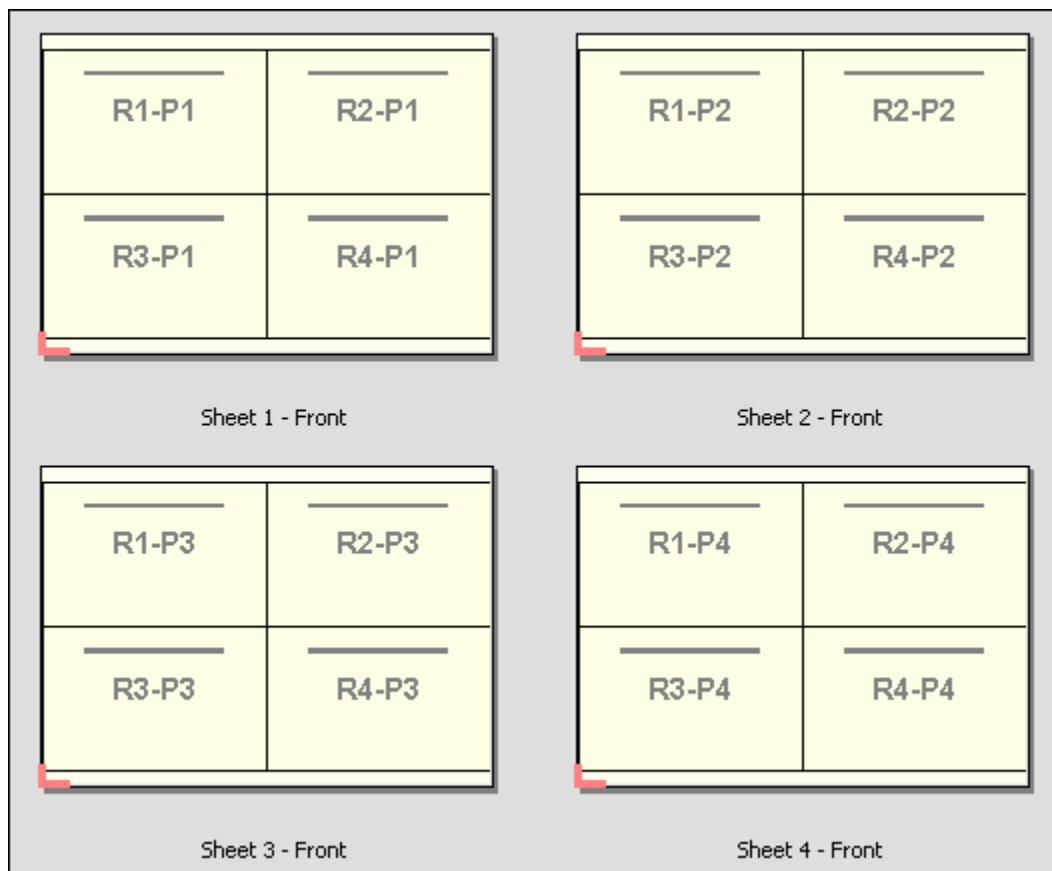

Cut and Stack

Cut and Stack arranges pages on the sheet surface so that the sheets can be stacked and cut, and the cut piles stacked without any additional sorting. The **Cut and Stack** layout can be used with the **Stack size** option.

The following example shows a 2-by-2, simplex, **Cut and Stack** layout applied to a VDP job that contains 100 records. Each record consists of one page. When the sheets are stacked, cut, and stacked again, the records are arranged in sequential order.

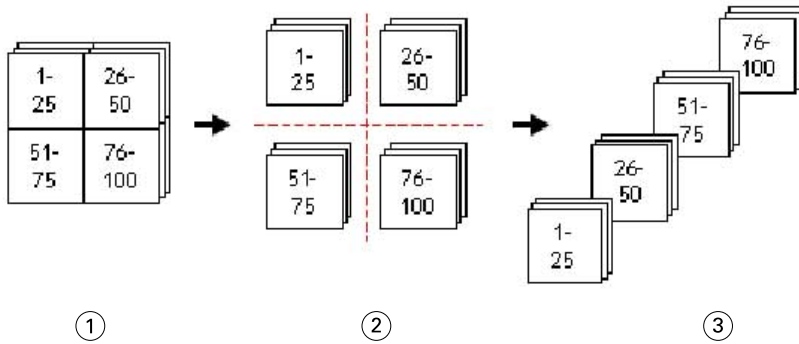

- 1 Print
- 2 Cut
- 3 Stack

Stack size

Stack size divides large VDP jobs into smaller batches to simplify the resulting **Cut and Stack** workflow. This lets you limit the stacked sheets to quantities that are accommodated by standard cutting machines. Each batch is imposed independently using the **Cut and Stack** layout, and separator sheets are placed in between the batches. (The **Stack size** option is only available when you choose the **Cut and Stack** layout.)

The following example shows a 2-by-2, simplex, **Cut and Stack** layout applied to a VDP job that contains 12000 records, each consisting of a single page. This results in 3000 sheets. The **Stack size** option is set to 1500 sheets per batch. The resulting layout consists of two batches, each of which can be cut, sorted, stacked, and packed in tandem.

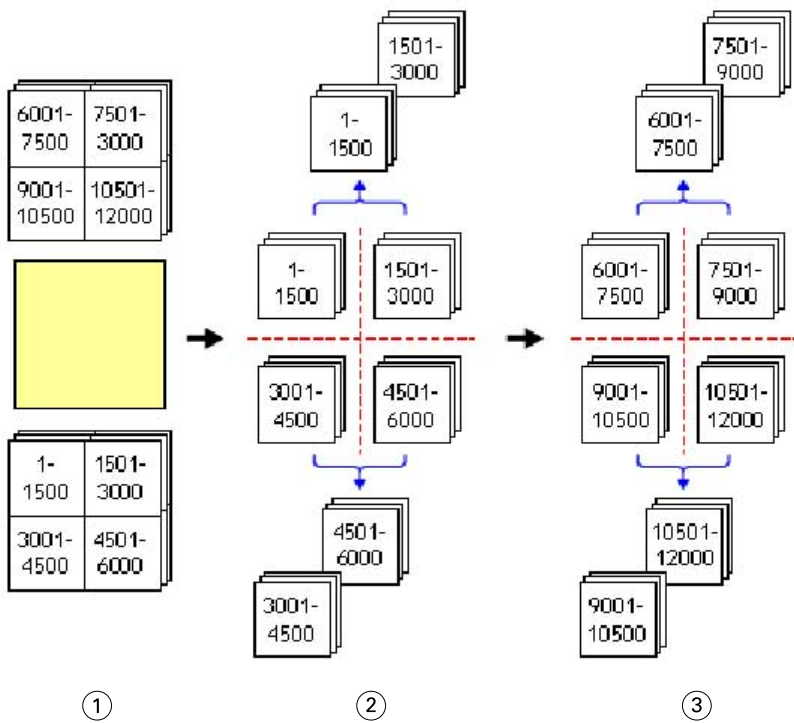

- 1 Print
- 2 Cut first pile and pack
- 3 Cut second pile and pack

Imposition settings

Fiery Impose lets you set print job options including finish size, sheet size, duplex, scaling, cover media, layout orientation, bleeds, and printer's marks.

The settings that are displayed in the **Settings** pane are determined by the product intent you choose. See [Choose a product intent workflow](#) on page 52.

For a description of the templates available for each product intent, see [Imposition templates](#) on page 26.

Choose a product intent workflow

Fiery JobMaster, Fiery Impose, and Fiery Compose supports a variety of workflows (product intents). When you choose a product intent, the **Settings** pane changes to show the options relevant to that product intent.

- 1 Click the arrow in the product intent box at the top of the **Settings** pane under **Template**.
- 2 Select one of the following product intents:
 - **Compose**
 - **Normal**

- **Booklet**
- **Gangup**

3 Select any product intent style and method.

For example, if you chose **Booklet** for the product intent, choose the binding method and the binding side. If you chose **Gangup** for the product intent, choose the gangup option and the binding side.

4 If the **Finish Size** menu is displayed, choose a finish size.

The **Normal** and **Booklet** intents include a **Finish Size** setting that allows you to choose between a crop box finish size workflow and a user-defined finish size workflow. The **Gangup** intent includes an the **Based on Trim Box** setting for the **Finish Size** option.

Finish size options for Fiery Impose

Finish Size sets the size of the final product after printing and applying finishing processes such as trimming, folding, or binding.

The default workflow is **Based on Crop Box**.

The possible workflows are:

- **Based on Crop Box** - The layout of the job is referenced to the Adobe PDF crop box. You must manually set the bleed size for the selected document page content. In this finish size workflow, you must manually estimate the finish size of the final product by subtracting bleed size from the size of the crop box.
- **User Defined** - The final finish size and bleed size are automatically detected for the PDF job, but you can change both settings. The page content is aligned in the center of the media. In the **User Defined** finish size workflow, the finish size is a static value independent of bleed, crop box, or document page size. The original bleed sizes are automatically detected.
- **Based on Trim Box** - This is an automated workflow that dynamically creates the layout for different smaller-sized items (such as business cards, postcards, or concert tickets) on a larger-sized sheet (such as 11x17). You can create one hot folder per sheet size and drop in different smaller-sized items. Automatic orientation determines the best orientation, so that the maximum number of items can be printed. This workflow applies only to gangup jobs.

When you change the finish size to **Based on Trim Box**, the layout orientation is automatically set to **Automatic**. **Automatic** calculates the number of items that can be printed in either portrait and landscape and then uses the orientation that maximizes the sheet space. For example, if you print business cards that are 3.5x2 inches on a 12x18 sheet, there could be 24 business cards in portrait (eight rows and three columns), or 25 business cards in landscape (five rows and five columns). The **Automatic** setting chooses landscape, which is the orientation that produces the most business cards. **Automatic** is not available for other finish size workflows.

The minimum dimension you can enter for the final finish size is 0.25 inches. The maximum depends on the paper size supported by the printer.

Advantages of the User Defined finish size

The user-defined finish size is based on the trim size specified in the original content. You specify the finish size and Fiery Impose automatically positions the page content in the center of each sheet.

If the job being imposed comprises content positioned differently on each page, each with a different crop size, selecting the user-defined finish size allows Fiery Impose to automatically pick up the trim size set in the Adobe PDF.

With the crop box finish size workflow, the user must figure out the bleeds and do some manipulation to place the page content correctly for the imposition layout.

Advantage of the Based on Trim Box finish size

An advantage of the **Based on Trim Box** finish size, particularly with automated workflows such as Fiery Hot Folders, Virtual Printers, and Presets, is the automatic recalculation of rows and columns if you change the size of the PDF image. Automatic layout orientation maximizes the number of products (such as business cards). If you change the sheet size when setting up the workflow in Fiery Impose, the layout updates.

Set sheet size in Fiery Impose

The default **Sheet** setting applies to all sheets (signatures) and defines the dimension of the intended imposition layout. Special sheet size assignments can be defined in Media Catalog, Paper Catalog, or **Mixed Media** in the **Job Properties** window.

- 1 Select the dimensions of a sheet of paper in the **Sheet** menu.
You can also type the desired size directly into the **Sheet** option menu.
- 2 Click **Edit** to specify other media settings, such as weight and color mode.
- 3 If Media Catalog or Paper Catalog is supported, select **Choose from Media Catalog** or **Choose from Paper Catalog** from the **Media** menu.

Duplex settings in Fiery Impose

Duplex sets how to handle content on opposing sides of a sheet. You can set duplex for right and left binding, top binding, or turn duplex off. **Duplex** options depend on the connected Fiery server.

Fiery Impose automatically applies duplex settings for the selected booklet style and binding. The **Duplex** setting in Fiery Impose overrides any **Duplex** setting performed in Command WorkStation **Job Properties**.

- Select one of the following:
 - **Off** - turns off duplex printing and uses simplex printing.
 - **Right & Left Binding** - sets duplex printing with both sides of the pages printed with the same orientation. Right and left binding are not available for some imposition settings.
 - **Top Binding** - sets duplex printing with the content on the each side of the page oriented upside down from the other side. Top binding is not available for all jobs.

Note: **Duplex** may not show **Sheet View** with the orientation it will have when printed. For example, top binding duplex may be displayed as both sides of the page right-side-up.

Scale settings in Fiery Impose

Scale settings enlarge or shrink the page by a specified amount.

In **Compose** and **Normal** product intents, the **Scale** settings apply to all pages in a job. In **Booklet** and **Gangup** product intents, you can apply scaling to specific slots on sheets. The number of slots on a sheet depends on the **Row** and **Column** values. The slot size equals the maximum imageable area of the sheet divided by the number of slots.

The **User-Defined Finish Size** workflow provides more scale options than the **Crop-Box Finish Size** workflow.

The **Use non-printable area** option uses the selected sheet's full physical dimensions for imposing your print job. This is helpful when creating custom templates that you may want to use with a variety of printers.

When this option is not selected, Fiery Impose determines position and scale factor of the imposed job by the imageable area of the final printed sheet, according to the printer. This constraint may prevent a custom template being used with another printer.

Note: The **Layout Rows & Columns** values interact with the **Scale** settings. If you choose a value that causes content to extend beyond the edge of the sheet, Fiery Impose provides a visual warning.

Scaling options

When you open a job in Fiery Compose or Fiery JobMaster, the job retains the scale percentage applied in the **Job Properties > Layout > Normal** tab.

Scaling in Fiery Compose or Fiery JobMaster has the following options:

- **Do not scale** - scaling is not applied and the page content is printed as-is.
- **Scale to fit (Paper size)** - scales the page content to fit the physical dimensions of the sheet. The scale is calculated by referencing the page content and the selected sheet size. This option is available when you select **Compose** as the product intent.

Note: The sheet size can be selected from the **Sheet** drop-down, in the **Settings** pane.

- **Scale to fit (Imageable area)** - scales the page content to fit within the imageable area on the selected sheet size. The scale is calculated by referencing the page content and imageable area available on the selected sheet size. This option is available when you select **Compose** as the product intent.

Note: To view the imageable area, click the **Show measurement of page elements** icon on the toolbar, in the **Sheet View** pane.

- **Custom** - scales a percentage to your desired scale value in the **Scale Factor**. Setting a **Scale Factor** to 100% is equivalent to the **Do not scale** scaling option.

Specify the scale settings

You can specify scaling, scale to fit, or prevent scaling using the default setting, **Based on Crop Box**, for the **Finish Size** option. The **User Defined** finish size workflow provides more scaling options, letting you fit or fill the page image to the static boundary of the finish size or bleed.

- 1 Select a setting from the **Scale** menu.
- 2 If you chose **Custom**, type a scale value in the **Scale Factor** text field.

- 3 To use the selected sheet's full physical dimensions for imposing your print job, select the **Use non-printable area** check box if it is available.

Set the cover media

You can set whether to include a cover and specify its settings.

- 1 Select the **Cover** check box to include a cover.
- 2 Choose whether to apply the same settings for both front and back covers, specify settings only for the front cover, or specify separate settings for the front and back covers in the **Cover Media** window.
- 3 Click **OK** to apply your settings.

You can click **Define** to open the **Cover Media** window again and change your settings.

Set the layout orientation

You can use the **Layout Orientation** menu in the **Settings** pane to specify the orientation of a sheet.

- 1 In the **Layout Orientation** menu, select one of the following:
 - **Portrait**
 - **Landscape**
- 2 If the booklet style is **Nested Saddle**, specify the **Subset size** option, which is the number of sheets within each subset.

The number of sheets for the last subset is not a fixed number, and Fiery Impose adjusts the sheets needed according to the actual page count of the job. The default **sheet(s)/subset** setting for the **Subset size** option is **2** and the maximum value is **15**.

Bleeds for workflows in Fiery Impose

How Fiery Impose applies bleeds depends on the workflow you set.

- For the **Based on Crop Box** finish size workflow, the **Bleed** option moves the trim marks into the image by the amount you specify to ensure that the printed area extends beyond the edge of the trimmed sheet. You can specify separate bleed amounts for the left or right (horizontal) and top or bottom (vertical) edges of the page content.
- For the **User Defined** finish size workflow, the **Bleed** option represents the amount of page content to be shown beyond the boundary of the finish size. The trim marks adjust automatically and remain aligned to the edge of the finish size. When a job is opened in Fiery Impose and the **User Defined** setting is selected for **Finish Size** option, the dimensions of the finish size and the bleeds are automatically entered, but you can change the settings.

Set bleeds

Fiery Impose lets you set horizontal and vertical bleeds.

- Do one of the following:
 - To specify separate horizontal and vertical bleed amounts for a job, enter values from 0 to 720 points, 0 to 10 inches, or 0 to 254 mm in the appropriate fields.
 - To apply the same bleed values to all four edges of the page content, click the **Apply Both** check box and type a value.

Offset the layout

Using the **Layout Offset** option, you can specify the distance between the edge of the sheet and the layout trim box on all four sides of the sheet. The **Layout Offset** option repositions the layout on the sheet, where the size of the layout area remains unchanged.

Note: The offset values specified in the **Layout Offset** window are applied to all sheets in the job.

Note: The **Layout Offset** option in the **Marks** window, in the **Registration Mark and Barcode** tab, cannot be used with conjunction with the **Layout Offset** option in the **Settings** pane. If you specify the offset values in the **Settings** pane, Fiery Impose automatically disables the **Layout Offset** option in the **Marks** window.

- 1 In Fiery Impose, in the **Settings** pane, click **Define** for the **Layout Offset** option.
- 2 Specify the offset values in the **Layout Offset** window.
- 3 Do one of the following:
 - If the specified values are correct, click **OK** to apply the changes.
 - If the specified value are incorrect, click **Reset** to discard the changes.
 - If you do not want to offset the layout, click **Cancel**.
- 4 If the offset values applied are incorrect and you want to undo the applied offset, select **Edit > Undo Layout Offset**.

Set margins

Margin is the distance between the sheet edge and the layout edge. You can set your desired margins on the sheet to leave enough space on any side of the sheet.

Using **Custom** margin, you can specify different margin values on all four edges of the sheet and use the additional space on the sheet for the finisher gripper to hold the sheet for processing.

- In Fiery Impose, in the **Settings** pane, select one of the following in the **Margin** option.
 - **Default** - sets the margins automatically to the default values. The default values accommodate the non-printable area.
Note: The space available between the sheet edge and the layout edge is the non-printable area.
 - **Use Non-printable area** - sets the margins automatically to zero. If you select this option, the layout edges align with the sheet edges using the non-printable area, thus allowing for printing to the edge of the sheet. All margins display a zero value.
Note: The sheet's non-printable area is a device dependent value. If you select **Use Non-printable area** option, clipping may occur in the final printing result.
 - **Custom** - allows you to manually set the margins to your desired values. If you select this option, you can manually specify the left, right, top, and bottom margin values. The **Custom** option allows you to leave enough space around the layout to accommodate finisher-related requirements.
Note: Margins specified are applied to all pages in a job.

Set printer's marks in Fiery Impose

Fiery Impose allows you to set printer's marks. You can also turn on or turn off marks and individual elements of the job label.

A dotted line defines the location of a fold on a layout called a fold mark; a solid line defines the location of a cut called a trim mark. Specialized marks also define the size and locations of margins (space surrounding the page's content area), gutters (space between pages), and bleeds (extensions of content beyond a trim mark), used to ensure that the printed area extends to the very edges of a trimmed page. You can choose between standard style trim marks or Japanese style marks.

- Use printer's marks to add trim, fold, and job information to all sheets in a job. The printer's marks option turns printer's marks on globally throughout a job. Layouts display only the relevant printer's marks. If the layout does not require folding the sheet, fold marks are not displayed, even if you selected them.
- Use the **Marks** window to turn on or turn off trim marks, fold marks, and the individual elements of the job label.

Note: Printer's marks in the **User Defined** finish size workflow always align to the edge of the finish size.

About named sets of marks in the Marks menu

Named sets of marks can be saved to your local computer or can be a unique set of marks for a specific job.

Names in the **Marks** menu can be:

- **None** - no marks to be applied.
- A list of names that you used when saving sets of marks on your local computer.

Note: By default, names are sorted in alphanumeric ascending order.

- **Custom** - marks that are unique to the job or have not been saved as a named set of marks on your local computer.

If you open a job with a named set of marks (called, for example, “Blue Marks”) and then you use the **Marks** menu to change one of the settings, the changed set of marks is no longer named “Blue Marks” and is instead named “Custom”. If you save this changed set of marks, you can give the set a new name. If you try to name it “Blue Marks”, Fiery Impose asks you whether you want to overwrite the existing set named “Blue Marks”.

If you change the settings in “Blue Marks” after saving a job, when you next opens that job, the name of the set of marks shows as “Custom”. If you delete a named set of marks after saving a job, when you next open that job, the name of the set of marks shows as “Custom” but the settings in the job are not lost.

Note: The named sets of marks that you create are saved on your local computer. Names of sets of marks do not transfer between user computers. For example, you can create a set of marks called “Blue Marks” on your local computer and assign it to a job. Another user opens that job on her local computer. Even if the other user also has a set of marks called “Blue Marks” on her computer, the set of marks in your job still shows as “Custom” in the **Marks** menu on her computer.

Name, save, and reuse sets of marks

You can apply mark settings and name, save, and reuse sets of marks, including style, horizontal length, vertical length, stroke type, stroke width, and stroke color.

- 1 Select **Define** in the **Marks** menu.
- 2 In the **Marks** window that appears, add printer marks or custom objects onto the sheet layout, and click **Save**.
A message appears asking you to name the set of marks.
- 3 Name the set of marks. This name will appear in the **Marks** menu in the future, allowing you to use the named set of marks for future jobs.
- 4 Click **OK** in the **Marks** window to apply the set of marks to the current job.
To delete a set of marks, select the set that you want to delete from the **Marks** menu, and click the trash can icon.

Define printer's marks

You can use the **Marks** window to set printer's marks.

- 1 In the **Settings** pane, click the **Marks** menu and select **Define**.
- 2 Use the **Trim**, **Fold**, **Job Label**, **Blank Page Text**, and **Registration Mark and Barcode** tabs to specify settings.

Note: The **Job Label** for VDP jobs displays different information than for non-VDP jobs.

Set trim marks

You can use the **Trim** tab to set trim marks.

- 1 Click the **Trim** tab.
- 2 Select the **Print trim marks** check box.

3 Select from the **Style** menu:

- **Standard** - prints the marks in a standard western style format (single marks at the corners). This is the default setting.
- **Japanese** - prints marks in a Japanese style format (marks at the corner and in the center of each side of the page).

If the bleed value is 0, the Japanese marks are one line, similar to the standard style. If a bleed value is set, two corner marks are displayed, to indicate the trim and the bleed.

4 Set the following for the printed trim marks:

- Set the horizontal and vertical mark length from 1 to 216 points.
- Set dotted or solid for **Stroke type**.
- Set **Stroke width** from 1/4 to 3 points.
- Set **Stroke color**.
- In the horizontal and vertical **Offset** fields, enter values from -72 to +72 points, -1.0 to 1.0 inch, or -25.4 to 25.4 mm.

Set Fold marks

You can set fold mark length and appearance, and disable individual marks in the **Fold** tab.

1 In the **Marks** window, click the **Fold** tab.**2** Select the **Print fold marks** check box.**3** Set any of the following:

- Set the horizontal and vertical lengths of marks from 1 to 216 points.
- Set **Stroke type** of fold marks to either dotted or solid.
- Set **Stroke width** of fold marks from 1/4 to 3 points.
- Set the **Stroke color**.

Set job label attributes

You can set job label content and location in the **Job Label** tab. Job label content for VDP jobs differs from non-VDP jobs.

1 Click the **Job Label** tab.**2** Select any of the following check boxes to display the associated information on the job label:

- **Print job label**
- **Job Name**

- **Sheet Info**
- **Date & Time**

Note the following:

- Sheet information for standard jobs includes the sheet number and the surface information (front or back).
- For VDP jobs, you can also click the **Output sheet number** check box, which displays the absolute sheet number. If the total number of printed sheets is 500, the absolute sheet number is from 1 to 500.

- 3 Click the area where you want to place the label.
- 4 Click **Horizontal** or **Vertical** to set whether the job label is placed horizontal or vertical on the sheet.
- 5 (Option) Type the offset X and Y values.
The offset is measured from the point of origin.

Set blank page text

You can set what shows on implicit blank pages in the **Blank Page Text** tab.

- 1 Click the **Blank Page Text** tab.
- 2 Select the **Print blank page text** check box.
- 3 Type text you want to appear on any implicit blank pages.

Set registration marks and barcode in Fiery Impose

Your imposed layout can include a registration mark, a barcode, or both. These options allow automatic drift compensation and machine setup for the Duplo offline finisher.

The registration mark position determines the leading edge of the sheet, as the Duplo finisher requires the mark to be on the right of the leading edge of the upper surface of the sheet.

- 1 In Windows, select **Fiery Impose > Edit > Preferences > Finishers**. On macOS, preferences are in the Fiery Command WorkStation menu in the **Fiery Impose** or **Fiery JobMaster** window.
- 2 In the **Finishers** tab, click one of the following in the **Select device** field:
 - **Duplo DC-646 (2-digit barcode)**
 - **Duplo DC-646 (3-digit barcode)**
 - **Custom**
 - **[User-installed device profile name]**
- 3 In the Fiery Impose **Settings** pane, select **Define** in the **Marks** list.
The **Marks** window opens.
- 4 In the **Marks** window, click the **Registration Mark and Barcode** tab.

5 Click one of the following in the **Print** field:

- **Do not print**, which is the default
- **Registration mark only**
- **Barcode only**
- **Registration Mark and Barcode**

The options in this dropdown are displayed or hidden based on the device capabilities.

6 If you set **Registration mark only**, set the following:

- **Position** - location of the registration mark on the sheet.
- **Mark length** and **Mark width** - possible length is from 5 to 10 mm. The possible width is from 0.4 to 1.6 mm.
- **Mark Offset** - vertical and horizontal offset for the mark position. The default for both **feed edge** and **right edge** is 5 mm. The possible range is 3 to 15 mm for each.
- **Layout Offset** - amount to move the layout away from the feed edge of the sheet to accommodate the registration mark and barcode. The possible range is 0 to 30 mm.

7 If you set **Barcode only**, set the following:

- **Position** - barcode location on the sheet.
- The **Barcode Text** and **Barcode Type** values vary based on the device selected in **Edit > Preferences > Finishers > Select device**.
 - If you set **Duplo DC-646 (2-digit barcode)** in **Edit > Preferences > Finishers > Select device**, set the following:
 - **Barcode Type** - default is Code 39
 - **Barcode Text** - a two-digit number from 01 to 80
 - If you set **Duplo DC-646 (3-digit barcode)** in **Edit > Preferences > Finishers > Select device**, set the following:
 - **Barcode Type** - default is Code 39
 - **Barcode Text** - a three-digit number up to 250
 - If you set **Custom** in **Edit > Preferences > Finishers > Select device**, set the following:
 - **Barcode Type** - Code 39 or Code 128
 - **Barcode Text** - supports a combination alphanumeric characters and special characters. The special characters allowed are hyphens, periods, dollar signs, forward slashes, plus sign, percent signs, and spaces.
 - If you select a [user-installed device profile name] in **Edit > Preferences > Finishers > Select device**, the **Barcode Type** and **Barcode Text** values must be set according to the device specification provided by the device manufacturer.
- **Print Text** - prints the numerical representation of the barcode on the sheet.

- **Mark Offset** - vertical and horizontal offset for the barcode position. The default for **feed edge** is 5 mm, and the possible range is 3 to 15 mm. The default for **right edge** is 25 mm, and the possible range is 25 mm to 42 mm.
 - **Layout Offset** - amount to move the layout away from the feed edge of the sheet to accommodate the registration mark and barcode. The possible range is 0 to 30 mm.
- 8** If you specified **Registration Mark and Barcode**, specify the settings in the **Registration** pane as described in steps **6** on page 62 and **7** on page 62.
- The settings apply for both registration marks and barcodes. In the **Barcode** pane, specify the text and whether to print the text.
- 9** Select **Print mark on front surface of sheet only**, if required.

Specify booklet settings in Fiery Impose

Booklet settings include binding settings for booklet product intent, rows and columns, and creep (the shift of the content area caused by the incremental fold of signatures in Saddle and Nested Saddle binding).

Specify binding settings for Booklet

You can specify a binding method and edge options. The binding method affects the order in which pages are placed on the sheet. There are no binding selections available for layouts with more than two columns or rows.

- 1** Set one of the following binding methods:
 - **Saddle**
 - **Nested Saddle**
 - **Perfect**
- 2** Set one of the following binding edge options:
 - **Left binding**
 - **Right binding**
 - **Top binding**

Note: Top edge binding is available only when the layout setting is either two rows by one column or two rows by two columns.

Specify row and column settings for booklet product intent

For booklet **Layout Row & Column** settings, you can specify **1 x 2**, **2 x 2**, or **2 x 2 Repeat Booklet**.

- 1** Select the **Layout Row & Column** menu.

2 Select 1 x 2, 2 x 2, or 2 x 2 Repeat Booklet.

Which settings are available depends on the binding style.

3 Select the Align to center check box to define the initial placement of the page content.

If specifying a creep setting, and selecting **In**, you can use **Align to center** to space the imposed page or specify a gutter to indicate the amount of creep.

Styles available for edge-binding options

The following table shows which **Style** settings can be used with the edge binding options. These are applicable for PostScript or PDF jobs, but not for VDP jobs.

Note: For the **Repeat Booklet** binding layout, the **Style** setting modifies the orientation of the booklets. For **Gangup** layouts, the **Style** setting modifies the orientation of the pages.

Binding Method	Standard	Head to Head	Foot to Foot	Reversal	Reversal Alternate
Left Edge Binding	Yes	Yes	Yes	No	No
Right Edge Binding	Yes	Yes	Yes	No	No
Top Edge Binding	Yes	No	No	Yes	Yes

Specify creep settings

For the **Creep** option, you set a direction and sheet thickness.

1 In the Creep menu, select one of the direction settings:

- **None** - Creep adjustment is not applied.
- **In** - The positions of pages on the outermost sheet remain constant. The positions of the remaining pages on all other sheets move toward the spine.
- **Out** - The positions of pages on the innermost sheet remain constant. The positions of the remaining pages on all other sheets move away from the spine.

2 Set sheet thickness by doing one of the following:

- Click an option in the creep adjustment menu.
- Type a custom thickness value between 0 pt. and 2 pt. or the equivalent in another measurement unit.

Automatic page rotation for imposed, mixed-orientation jobs

The Automatic page rotation feature lets you easily create a booklet, or another finished job, from a mixture of landscape and portrait pages. You can easily arrange the booklet so that the orientation of all pages is the same and no page content is clipped.

This feature works with Normal, Gangup, and Booklet workflows using either user-defined or based on trim box finish size. It does not work with VDP workflows or custom rotation.

- 1** In the Fiery Impose **Settings** pane, create a booklet by selecting **Booklet** (with the defaults, **Saddle** and **Left**), and set the **Finish Size** to **User Defined**.
- 2** Select the sheet size.
- 3** In the **Auto Page Rotation** menu, select one of the following auto rotation directions:
 - **90 degrees clockwise**
 - **90 degrees counter-clockwise**
- 4** Under **Scale**, select **Fit finish size proportionally**.
- 5** Click the save icon at the top of the **Settings** pane.
- 6** Type a name for the template and save as a regular imposed job.
- 7** Click **OK**.
- 8** Close the job without saving it.
- 9** Open Fiery Hot Folders.
- 10** Click **New** to create a new hot folder.
- 11** Type a name for the hot folder in the **Hot Folder Settings** window.
- 12** Click **Select** and then click **Connect** to connect to a Fiery server.
- 13** Select **Process and Hold** in the **Job action** menu.
- 14** Select **Define** for the **Job Properties** option.
- 15** In the **Job Properties** window, select **Layout > Impose**.
- 16** Select the template that you created for the **Templates** option.
- 17** Click **OK**.
- 18** In the **Hot Folder Settings** window, click **OK**.

The hot folder is created on the desktop.
- 19** On the desktop, drag the job with mixed page orientations into the hot folder.
- 20** Go to the Fiery server. The job should appear there and be processed.

Modify pages manually in Fiery Impose

When you use Fiery Impose, you can manually rotate, edit reorder, insert, and delete pages.

Rotate pages

In the **Sheet View** pane, you can only rotate pages in wire frame mode.

- Do any of the following:
 - To rotate a single page, click the **Rotate** icon on that page.
If you zoomed out too far, you may not see the **Rotate** icon. You can zoom in until the icon becomes visible.
 - To rotate all pages in the job, press the **Shift** and **Ctrl** keys and click the **Rotate** icon on any page.
 - To rotate all pages in a certain location on the front side of each duplex sheet, press the **Shift** key and click the **Rotate** icon on any page in that location on any sheet.
 - To rotate all pages in a certain location on the front and back sides of each duplex sheet, press the **Ctrl** key (Windows) or **Cmd** key (macOS) and click the **Rotate** icon on any page in that location on any sheet.

Open a job for editing in Acrobat

Fiery Impose can open a job for editing in Adobe Acrobat Pro.

- Right-click a page in the **Page View** pane and then click **Edit in Acrobat**.

Reorder pages

You can reorder individual pages manually by arranging them in the main window.

- In the **Page View** pane, select the thumbnail you want to move, and then drag the page to its new position.

Insert blank pages manually

You can add a blank page to your layout.

- Select the page in the **Page View** pane where you want to add a page, and then click the **Insert Blank Page** icon in the **Page View** toolbar.

Delete pages

You can quickly delete pages.

- Right-click a page in the **Page View** pane and choose **Delete** from the menu that appears.

VDP in Fiery Impose

In Fiery Impose, Variable Data Printing (VDP) imposition uses many of the features available for a normal imposition job. However, there are differences between VDP and normal imposition, and differences in the Fiery Impose window.

A Variable Data Printing (VDP) job consists of one or more variable-data records.

Fiery Impose lets you impose jobs saved in any of the following VDP formats:

- FreeForm 1.0 and FreeForm 2.1 (FreeForm 2.0 is not supported.)
- FreeForm Plus
- VPS
- PPML
- PDF/VT

You can impose VDP jobs using predefined templates or custom templates created in Fiery Impose.

When you apply a template to a VDP job, the template's imposition layout is applied in sequence to each record in the job.

- Each record begins on a new sheet.
- If a record does not fill the sheet completely, Fiery Impose inserts one or more blank pages to compensate for remaining slots on the sheet surface.
- The number of pages in each record can vary. Fiery Impose inserts blank pages to compensate for differences in page length among records.

Open or preview a VDP job

You can open a VDP job from the Job Center **Held** list. To preview a processed VDP job, use the **Raster Preview** window.

- Do one of the following:
 - To open a VDP job, right-click it in the Job Center **Held** list.
 - To preview an open VDP job, use the **Raster Preview** window (**Actions > Preview**).

Previews include any imposition settings applied to the job. The job content display is actual size, organized by records or finished sets.

Imposing a VDP job

Imposition settings apply to each page of the VDP job. Many VDP imposition settings are similar to those for a non-VDP job.

Note: **Normal**, **Booklet**, and **Gangup** are the workflows (product intents) available for VDP imposition. **Compose** is not available.

When you impose a VDP job, note that:

- The **Sheet Size** menu includes the currently selected sheet size and most recently used sheet sizes.
- The **Template** menu lets you select a predefined template or a custom template created with Fiery Impose.
- When you create a custom template in the **VDP Imposition** window, you must have a VDP job open to access the VDP-only features.

Print control strips for VDP jobs

A control strip identifies absolute surface number, output-set number, surface number relative to start of output-set, and logical pages for each record.

- Click **Marks** and then click **Define**.

Specify booklet, scale, or bleeds for VDP imposition

VDP imposition settings for multi-up booklet, bleeds, and scale differ slightly from the settings for a standard Fiery Impose job.

Set multi-up booklet for VDP jobs

You can specify a **2 x 2 Unique Booklet** when you select **Saddle** for a VDP job. This lets you print two records on a sheet. For records of different lengths, Fiery Impose automatically adds blank pages based on pagination requirements.

You can save the settings as a preset that you can select from Virtual Printers or Fiery Hot Folders.

- 1 Select a job in the **Held** list in Command WorkStation and open Fiery Impose in one of the following ways:
 - Select **Impose** from the **Actions** menu.
 - Right-click the job and select **Impose**.
- 2 In the **Fiery Impose** window, click **Booklet** for the product intent, and **Saddle** for the binding type.

- 3 Select one of the following binding styles:
 - **Left**
 - **Right**
 - **Top**
- 4 Click **Edit** to specify sheet size for the **Sheet** option.
- 5 Click **Cover** to specify cover settings.
- 6 In the **Cover Media** window, select one of the following for the **Front Cover** and **Back Cover** options:
 - **None**
 - **Inside**
 - **Outside**
 - **Both Sides**
- 7 Click **OK**.
- 8 Specify the **Layout Orientation**.
- 9 Select **2 x 2 Unique Booklet** for the **Layout Row & Column** option.

Note: **2 x 2 Unique** booklet is only available for VDP jobs. If you are imposing a PostScript or PDF job, and using the same template, the setting defaults to **2 x 2 Repeat** booklet.
- 10 Specify other settings as required.

Set bleeds or scaling in VDP imposition

Setting bleeds in VDP imposition affects trim mark location. By default, Fiery Impose places the trim marks at the edge of the image. If you apply bleed values for VDP imposition, the trim marks are offset automatically by the amount of the bleed.

- Do any of the following:
 - For **Bleed**, enter the bleed values in the **Horizontal** and **Vertical** fields.
 - In the **Scale** pane, from the **Scaling** menu, select **Scale to Fit**, **100%**, or **Custom**.
If you chose **Custom**, enter a scale factor in the **Scale Factor** field.

Gangup settings for VDP imposition

For VDP imposition, you can process **Gangup** printing at either the page level or the record level.

Choose one of the following:

- **Single Record Mode** - Applies imposition to one record at the same time. Fiery Impose performs **Gangup** operation to pages within a single record.
- **Multiple Records Mode** - Applies imposition to multiple records at a time. Fiery Impose performs **Gangup** operation to pages from multiple records.

Gangup	VDP Options VDP Gangup	Availability	Earlier version of Fiery Impose equivalent
Unique	Single Record Mode Multiple Records Mode	Enabled Enabled	Unique Multiple Records Gangup
Repeat	Single Record Mode Multiple Records Mode	Enabled N/A	Repeat N/A
Unique-Collate Cut	Single Record Mode Multiple Records Mode	Enabled Enabled	Unique-Collate Cut Stack and Cut
Duplo - Short Edge Feed	Single Record Mode Multiple Records Mode	N/A Enabled	N/A N/A
Duplo - Long Edge Feed	Single Record Mode Multiple Records Mode	N/A Enabled	N/A N/A

Single Record Imposition for VDP jobs

With **Single Record Imposition**, each record within a VDP job is imposed one record at a time. The same imposition scheme is repeated for every record.

Any imposed sheet (signature) contains pages from a single record only, and blank pages are inserted if pages from the record cannot completely fill the sheet.

Single Record Imposition for VDP jobs supports **Repeat Gangup**, **Unique Gangup**, and **Unique-Collate Cut**.

Figure 1: Example of single-record imposition using Repeat Gangup for 8 records, 2 pages per record, 1 row x 2 columns layout, simplex. R = Record, P = Page, S = Sheet.

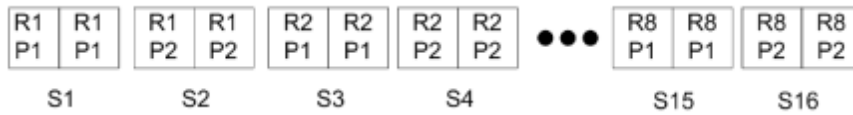

Figure 2: Example of single-record imposition using Unique Gangup for 8 records, 2 pages per record, 1 row x 2 columns layout, simplex. R = Record, P = Page, S = Sheet.



Figure 3: Example of single-record imposition using Unique-Collate Cut for 8 records, 4 pages per record, 1 row x 2 columns layout, simplex. R = Record, P = Page, S = Sheet.



Multiple Records Imposition for VDP jobs

With **Multiple Records Imposition**, multiple records within a VDP job are imposed onto one sheet. Multiple records are processed at the same time.

Multiple Records Imposition for VDP jobs supports **Multi-record Collate** and **Cut and Stack**. **Cut and Stack** allows you to position multiple records on the sheets so that the cut piles can be quickly stacked without further sorting. For a large job with many records, you can divide the job into sets for easier handling.

Figure 4: Example of Multi-Record Collate for 8 records, 2 pages per record, 1 row x 2 columns layout, simplex. R = Record, P = Page, S = Sheet



Figure 5: Example of Cut and Stack for 8 records, 2 pages per record, 1 row x 2 columns layout, simplex. R = Record, P = Page, S = Sheet



Duplo VDP Gangup

Duplo VDP Gangup layouts support the pagination scheme for the sheet-fed Duplo slitter/cutter/creaser finishing equipment. The Duplo gangup scheme creates pagination that lets you finish the printed sheets sequentially sheet by sheet.

Note: For **Duplo Gangup** layouts, the **Style** setting is unavailable, and you cannot specify a **Front Cover** or a **Back Cover**.

The available **Duplo Gangup** layouts are:

- **Duplo - Short Edge Feed** - Creates a pagination direction that lets you feed the final printed sheet into a Duplo finisher at the sheet's short edge.
- **Duplo - Long Edge Feed** - Creates a pagination direction that lets you feed the final printed sheet into a Duplo finisher at the sheet's long edge.

Integration with multi-functional finishing devices

Fiery Impose integrates with inline and offline multi-functional finishers that have slitter, cutter, creaser, and perforation capabilities. You can select a finishing device from **Fiery Impose > Edit > Preferences > Finishers**. Depending on the finishing device that is selected, you can perform one or a combination of the following tasks:

- [Set a registration mark and barcode](#) on page 72
- [Apply a finisher preset](#) on page 72
- [Create a finisher preset](#) on page 75

Note: Tasks are device-dependent, and you can perform these tasks only if supported by the selected finishing device.

Set a registration mark and barcode

Fiery Impose allows the use of only those types of registration marks and barcodes that are supported by the selected finishing device. You can insert a registration mark and barcode on an imposed layout. For more information, see [Set registration marks and barcode in Fiery Impose](#) on page 61.

Apply a finisher preset

There are two types of presets that you can apply to jobs:

- Finisher layout files in .xml format that are available for offline finishers or finishers without direct integration with Fiery Impose. These finisher layout files can be imported and saved as templates. For more information, see [About finisher layout files](#) on page 73.
- Existing presets that are available for inline finishers or finishers with a direct integration with Fiery Impose. For more information, see [Apply an existing preset](#) on page 74.

With both methods of applying presets, the imposition settings applied to the job are identical to the settings of the finishing device.

About finisher layout files

Finisher layout files contain information relating to layout settings that have been defined on the finisher. Some offline finishers support the export of layout settings to a finisher layout file.

When you export layout settings defined on a supported cut, trim, crease, or perforation finishing device to a finisher layout file, you can create Fiery Impose templates with identical layout settings. When you save the new template, you can apply the layout settings to future jobs without manual setup on the finisher.







Note the following:

- The Apply Finisher Preset feature is supported only on some inline and offline finishers.
- Importing of batch finisher layout files is not supported.
- By default, when finisher layout files are imported, they are saved as **User Defined** finish size imposition templates. The finish size set in Fiery Impose matches the dimensions of the cut block defined in the finisher layout file. Settings that modify the layout of the finish size imposition template are grayed out.
- When applying the template to a job, you can view the alignment of the page content and the finishing lines (fold and perforation line) in the Sheet View pane.

Finisher lines

In addition to layout parameters, the finisher layout file that is exported also contains information about line types.

The following table provides a reference to the types of finisher lines:

Line type	Tool ID	Sample
Crease	0: down 1: up	
Perforation	0: perforation 1: micro-perforation 2: slit-score (half-cut) 3: score (crease)	   
Fold	N/A	

Use a finisher layout file

- 1 Select a job in the **Held** list in Command WorkStation and open Fiery Impose in one of the following ways:
 - Select **Impose** from the **Actions** menu.
 - Right-click the job and select **Impose**.

2 In Fiery Impose, set preferences on:

- Windows: **Edit > Preferences > Finishers**.
- Mac computers: Preferences are under the Fiery Command WorkStation menu within the Fiery Impose window.

3 Select the **Allow finisher integration** check box to specify settings in the **Finisher integration** section.

You can clear this check box, when the finisher is not used.

4 In the **Finisher configuration** section, select the desired finisher from the **Select device** list.

5 Click **OK** and restart Fiery Impose for the changes to take effect.

6 Select **Actions > Apply Finisher Preset** or alternatively, click the **Finisher Preset** button at the top of the **Settings** pane.

7 Browse to the location of the finisher layout file and click **Open**.

Note: When a finisher layout file is imported, additional information about finisher lines is also stored in the finisher layout file. Some of the layout settings that are controlled by the finisher layout file are grayed out. All settings are enabled when either the Impose template is saved or when you click **Clear layout**.

After the finisher layout file is successfully imported, the name of the finisher layout file is displayed at the top of the **Settings** pane, below the **Template** list.

8 Specify additional settings not included in finisher layout file, such as setting the page level to duplex or simplex or defining the scaling factor.

9 Save the finisher layout as a template, a regular imposed job, or a flattened PDF.

Note: If you do not modify the imported file name, it will be shown as the name of the template.

10 Apply the template to jobs with the same finish size and bleed size using either Fiery Impose or workflows in Fiery Hot Folders, Server Presets, Virtual Printers, or Fiery JobFlow.

When applying the template to a job with Fiery Impose, you can view the alignment of the page content and the fold and perforation finishing lines.

11 After importing the finisher layout file, click the **Show finisher layout lines** button on the toolbar to display the finisher lines.

If you save the template at the time of import, the finisher line information is saved along with the Fiery Impose template and is available whenever the template is loaded.

Apply an existing preset

To apply an existing finisher preset, you must first select the **Allow finisher integration** option and specify the finishing device in **Fiery Impose > Edit > Preferences > Finishers**. For more information, see [About user preferences](#) on page 11.

1 Select a job in the **Held** list in Command WorkStation and open Fiery Impose in one of the following ways:

- Select **Impose** from the **Actions** menu.
- Right-click the job and select **Impose**.

- 2 In the Fiery Impose **Settings** pane, click **Finisher Preset**.

The **Finisher Preset** window opens.

- 3 Select a finisher preset from the **Finisher preset** list.

Note: Other areas in the **Finisher Preset** window are read-only. For more information about the **Finisher Preset** window, see [Specifying settings in the Finisher Preset window](#) on page 77.

- 4 Click **Apply** to apply the selected finisher preset to a job.

When applying an existing preset, settings on the **Layout**, **Crease**, or **Perforation** tabs are read-only. After applying the preset, some layout settings that are controlled by the preset are grayed out. You can click **Clear layout** in the **Settings** pane to remove the settings applied by the finisher preset.

Create a finisher preset

In Fiery Impose, you can create a finisher preset based on the configuration of your supported finisher. When you create a finisher preset, its layout settings are simultaneously validated against the limitations and constraints of the finisher. Thus, the preset that you publish is compatible with the finisher. The published preset is exported to the job queue of the Duplo PC Controller computer. When you apply the published preset to a job, the finisher can perform the necessary finishing functions on the printed output.

Note: This feature is currently supported only depending on your finisher.

To create a finisher preset, perform the following tasks:

- 1 [Set finisher preferences](#) on page 75
- 2 [Specify settings to create a finisher preset](#) on page 78
- 3 [Publish the finisher preset](#) on page 84

Set finisher preferences

To create a finisher preset, you must first specify preferences in the **Finishers** tab.

- 1 Select a job in the **Held** list in Command WorkStation and open Fiery Impose in one of the following ways:
 - Select **Impose** from the **Actions** menu.
 - Right-click the job and select **Impose**.
- 2 In Fiery Impose, select **Edit > Preferences > Finishers**.

Note: On Windows computers, you set Fiery Impose preferences in **Edit > Preferences**. On Mac computers, preferences are under the Fiery Command WorkStation menu in the **Fiery Impose** window.

- 3 Select the **Allow finisher integration** check box to specify settings in the **Finisher Integration** section.
You can clear this check box when the finisher is not used.
- 4 Select the desired finisher from the **Select device** list.

Note: Creating a finisher preset is currently supported depending on your finisher.

When you have selected your finisher, specify the following additional settings:

5 To access the installation folder located on the Duplo PC Controller computer, do one of the following:

- In **PC controller path**, specify the path to the installation folder on the Duplo PC Controller computer.

The installation folder contains configuration files with details about import and export folders that you created on the Duplo PC Controller computer.

- Click **Browse** to select the installation folder on the Duplo PC Controller computer and populate the **Preset path** field.

Note: The Duplo PC Controller computer requires a minor change in its configuration to enable the integration with Fiery Impose. For more information, see the documentation that accompanies the Duplo PC Controller software.

You can click **Test** to test the connection between the Fiery server and the computer with the Duplo PC Controller software.

You can also click **Import presets** to import backed-up or downloaded presets.

Note: The imported presets are listed in the **Finisher Preset** window.

6 Specify the number of perforation modules available on the finisher from the corresponding list.

Finisher module	Description	Supported finisher
CPM	The Cross Perforation Module (CPM) is an optional module installed on the finisher to support horizontal or cross perforation and horizontal scoring. Perforation is performed parallel to the feeding edge. If the job requires horizontal perforation, a minimum of one CPM module must be available for use on the finisher. To perform horizontal perforation, you must select the number of modules available on the finisher.	<ul style="list-style-type: none"> • Duplo DC-618
CPM	The Cross Tool Module (CPM) is an optional module installed on the finisher to support horizontal or cross perforation. Perforation is performed parallel to the feeding edge. If the job requires horizontal perforation, a minimum of one CPM module must be available for use on the finisher. To perform horizontal perforation, you must select the number of modules available on the finisher.	<ul style="list-style-type: none"> • Duplo DC-648
CRM	The Creaser Up Module (CRM) allows crease up (mountain), in addition to standard crease down (valley), horizontally across the sheet.	<ul style="list-style-type: none"> • Duplo DC-648
OSM	The Optional Slitter Module (OSM) provides up to 8 slits per sheet in combination with standard slitter modules.	<ul style="list-style-type: none"> • Duplo DC-648
PFM	In the PFM (Perforation Module - Vertical) module, perforation is performed in the direction that is perpendicular to the feeding edge. If the job requires vertical perforation, a minimum of one PFM module must be available for use on the finisher. To perform vertical perforation, you must select the number of modules available on the finisher.	<ul style="list-style-type: none"> • Duplo DC-618

Finisher module	Description	Supported finisher
RTM	RTM or the Rotary Tool Module is an advanced vertical perforation unit that can perform two perforations at a time on the right and the left side of the printed output. A maximum of two RTMs can be installed on one finisher.	<ul style="list-style-type: none"> Duplo DC-618 Duplo DC-648

7 In **Barcode Range Min** and **Barcode Range Max**, specify the minimum and maximum barcode range for the finisher preset.

Note: The barcode is used to identify the preset applied to a job. When you export a preset from the Duplo PC Controller computer, a barcode number is placed on the sheet when the job is printed. When you insert the printed output in the finisher, the scanner in the finisher scans the barcode and uses the preset number to automatically assign the correct preset to the job.

After specifying finisher preferences, you must restart Fiery Impose for the changes to take effect.

Specifying settings in the Finisher Preset window

To create a finisher preset, open a spooled job in Fiery Impose, and specify settings in the **Finisher Preset** window. In the **Finisher Preset** window, you can specify settings in three tabs: [Layout settings](#) on page 80, [Crease](#) on page 80, and [Perforation](#) on page 81.

Note the following:

- The applicable range of each setting that you specify is displayed in the status bar at the bottom of the **Finisher Preset** window.
- When you specify a setting in the **Finisher Preset** window, you can preview the changes in the **Sheet View** pane. If you do not specify the settings in the **Finisher Preset** window, default values are automatically set.
- You can navigate between settings and tabs sequentially. However, if you return to a previous setting or tab, all values and settings that you specified revert to default values.
- Diagnostic information, such as informational and warning messages, is displayed at the bottom of the **Settings** pane.

You can specify settings in the **Finisher Preset** window using the following controls:

Item	Description
Finisher model	View the name and model of the finisher that you have specified in Fiery Impose > Edit > Preferences > Finishers > Select device . Click View available modules to display the number of modules specified for CPM, PFM, and RTM. For more information, see Set finisher preferences on page 75.
Finisher preset	Select New preset or click Create new using to create a new preset from an existing preset. Existing presets are also available in this list. For more information, see Apply an existing preset on page 74. Note: Creating a finisher preset is supported only on some finishers.

Item	Description
Job/barcode number	<p>Specify the number that corresponds to barcodes that can be displayed on the sheet. When a new preset is created, the next available sequential number is automatically assigned to the preset.</p> <p>Note: Barcodes are finisher dependent.</p>
Setup	<p>Specify the number of horizontal perforation modules in the list on the left and the number of vertical perforation modules in the list on the right.</p> <p>Note: This option is available depending on your finisher.</p>
Layout settings tab	<p>Specify the layout settings of the finisher preset. For more information, see Specify settings in the Layout tab on page 80.</p>
Crease tab	<p>Specify the number of creases. For more information, see Specify settings in the Crease tab on page 80.</p>
Perforation tab	<p>Specify the number of horizontal and vertical perforations. Additionally, define patterns and segments that can be applied to each perforation. For more information, see Specify settings in the Perforation tab on page 81.</p>
Status bar	<p>View the valid range of each setting at the bottom of the window. You must enter a value within the valid range to be able to proceed to the next setting.</p>
Arrows	<p>Navigate between settings in tabs using the arrow keys on the keyboard.</p> <p>Alternatively, use the Tab key to navigate to the next setting and Shift+Tab to return to previous settings.</p>
Next and Back buttons	<p>Navigate between tabs.</p>
Apply button	<p>Apply the settings to the job.</p> <p>Note: Apply does not publish the layout as a preset. After the layout is applied to the job, you can select Clear layout or Publish in the Settings pane.</p>
Apply & Publish button	<p>Perform both Apply and Publish functions with one click. Apply & Publish appears in the Perforation tab. Specify settings in the Publish layout window and click Publish to generate a finisher preset based on the settings. This finisher preset is then exported to the Duplo PC Controller computer.</p>

Specify settings to create a finisher preset

You must specify settings in the **Finisher Preset** window to create a preset. For more information, see [Specifying settings in the Finisher Preset window](#) on page 77.

1 Select a spooled job in the **Held** list in Command WorkStation and open Fiery Impose in one of the following ways:

- Select **Impose** from the **Actions** menu.
- Right-click the job and select **Impose**.

2 In the **Settings** pane, click **Finisher Preset** to open the **Finisher Preset** window.

3 Click **View available modules** to display the number of modules specified for your finisher options.

The **Finisher model** displays the name of the finisher that you have specified in **Edit > Preferences > Finishers > Select device**.

For more information, see [Set finisher preferences](#) on page 75.

4 To create a preset, do one of the following:

- Select **New preset** from the **Finisher preset** list.
- Click **Create new using** to create a new preset from an existing preset.

Note the following:

- This feature is currently supported depending on your finisher.
- You can choose existing presets from the **Finisher preset** list. For more information, see [Apply an existing preset](#) on page 74.

5 In **Job/barcode number**, specify the number that corresponds to barcodes that can be displayed on the sheet.

Note: Barcodes are finisher dependent.

You can view the barcode range in the status bar at the bottom. When you create a new preset, the next sequential number is automatically assigned to the preset.

6 In **Setup**, specify the number of horizontal perforation modules in the list on the left and the number of vertical perforation modules in the list on the right.

Due to the number of slots available on the finisher, if you specify the horizontal perforation as **1**, for example, you can select only **1** as the vertical perforation module. However, if the job does not require horizontal perforation, select **0** in the horizontal perforation list and you can use up to 2 vertical perforation modules. Select **0** in both horizontal and vertical perforation lists if the job does not require perforations. The number of available slots depends on your finisher. The number of vertical perforations possible depends on whether any horizontal operation is required.

Depending on your selected finisher, you can select one of the following horizontal perforations:

- **Horizontal perforation (CPM)**
- **Horizontal crease up (CRM)**

Crease up and perforation cannot be used at the same time.

Note: For vertical perforation, the maximum number of modules available for use is determined by the values that you specify for PFM and RTM in **Fiery Impose > Edit > Preferences > Finishers**. For more information on PFM and RTM, see [Set finisher preferences](#) on page 75.

Specify settings in the Layout tab

- 1 From the **Sheet Size** list, select the size of the paper required for the job.

Sheet Size lists only the paper sizes supported by the finisher. When you select a size, you can preview the job on the selected paper size in the **Sheet View** pane. Click **Edit** to select other media-related specifications such as media type, weight, or color.

- 2 Select **Portrait** or **Landscape** from the **Finisher feed direction** list to set the feed direction of the sheet.

Note: The preview of the job in the **Sheet View** pane displays the arrow on the top that indicates the assumed feeding edge of the sheet.

- 3 Select the **Barcode** check box to display the barcode on the sheet when you print the job.

If you select this check box, the barcode that corresponds to the number selected in **Job/barcode number** is displayed on the sheet. By default, the barcode is displayed in the upper-right corner.

- 4 In **Finish size**, specify the size of the finished job. You can specify the width in the list on the left and the height in the list on the right.

- 5 In **Row and column**, select the number of rows and columns that you want to apply to the sheet.

Depending on the values that you specified in **Sheet Size** and **Finish size**, the number of rows and columns that can fit on the sheet is automatically calculated.

- 6 In **Gutter**, specify the vertical and horizontal gutter. You can set the gutter as either:

- **Fixed** - Set the same value for the horizontal and vertical gutter.
- **Variable** - Set different values for the horizontal and vertical gutter.

Note: Gutter refers to the space between two adjacent pages on a sheet.

- 7 In **Layout offset**, specify the distance between the top edge (feeding edge) of the sheet and the start of the job in the field on the left. In the field on the right, specify the distance between the right edge of the sheet and the start of the job.

Note: You should specify the **Layout offset** to accommodate the additional space required for finisher marks on the sheet.

- 8 Click **Next** to specify settings in the **Crease** and **Perforation** tabs. If the job does not require crease or perforation, do one of the following:

- Click **Apply** to apply the settings to the job.
- Click **Publish** in the **Settings** pane to generate a finisher preset and export the preset to the Duplo PC Controller computer.

Specify settings in the Crease tab

- 1 Select the number of crease lines that you want to apply to the finished product from the **No of creases** list. When you select the number of creases, **Crease position** settings are displayed.

- 2 In **Crease position**, specify the position of each crease on the finished product.

Depending on your finisher, keep the following in mind:

Finisher	Behavior
Duplo DC-618	<ul style="list-style-type: none"> • Depending on the number of creases that you selected in the No of creases list, corresponding rows of crease positions are displayed. • Crease position is calculated based on the distance from the leading edge of the finish size. • If you select None in the No of creases list, the Crease position setting is not displayed. • If there are multiple finished products in the layout, the number of creases that you selected is repeated on each finished product. • Vertical creases are not supported.
Duplo DC-648	<ul style="list-style-type: none"> • With the CRM module, the crease option can be set to either crease down or crease up.

3 Click **Next** to specify settings in the **Perforation** tab. If the job does not require perforation, do one of the following:

- Click **Apply** to apply the settings to the job.
- Click **Publish** in the **Settings** pane to generate a finisher preset and export the preset to the Duplo PC Controller computer.

Specify settings in the Perforation tab

You can apply horizontal, vertical, or a combination of horizontal and vertical perforations to jobs depending on their requirements. You must define a minimum of one pattern for a perforation. The pattern can be either one continuous perforation line or divided into smaller segments.

Settings in the **Perforation** tab are enabled only if you do the following:

- Specify the horizontal and vertical perforation modules in **Fiery Impose > Edit > Preferences > Finishers**.
- Specify the horizontal and vertical perforation modules in the **Setup** list in the **Finisher Preset** window.

Specify Horizontal perforation

1 In **No of horizontal perforation**, select the number of horizontal perforations required by the job.

When you select the number of horizontal perforations, the Y position settings are displayed. For more information, see [Y position](#) on page 82.

Note the following:

- The maximum number of horizontal perforations that you can apply to the job depends on the finish size.
 - If you select **None** in **No of horizontal perforation**, the Y position setting is not displayed.
 - If there are multiple finished products in the layout, the number of horizontal perforations that you selected is repeated on each finished product.
- 2** In **No of patterns**, select the number of horizontal perforation patterns.
- When you select the number of patterns, the pattern definition settings are displayed. For more information, see [Pattern definition](#) on page 82.
- Note:** When you select the number of horizontal perforations, **No of patterns** is automatically set to **1**. You can change this value as required.
- 3** In **Tool ID**, select the type and shape of perforation depending on the requirements of the job. Tool ID is device dependent.
- Note:** If the job requires horizontal perforation, you must first specify the **No of horizontal perforation**, **No of patterns**, and **Tool ID** settings to define the pattern and position of perforations.
- 4** In **Pattern definition**, define the number of segments in each perforation and the position of each segment. Depending on the number of patterns that you selected in the **No of patterns** list, corresponding rows of pattern definitions are displayed.
- **Segments** - Specify the number of segments required in the horizontal perforation.
 - **Position** - Specify the starting and ending position of each segment of the perforation. Position is calculated from the right edge of the finish size.
- 5** In **Y position**, specify the position of each horizontal perforation.
- Note the following:
- Depending on the number of horizontal perforations that you selected in the **No of horizontal perforation** list, corresponding rows of Y positions are displayed.
 - Y positions are calculated based on the distance from the leading edge of the finish size.
- 6** In **Select pattern**, choose from the list of defined horizontal perforation patterns.

Vertical perforation

You can perform vertical perforation using two different mechanical modules: PFM (Perforation Module) and RTM (Rotary Tool Module). PFM performs continuous, end-to-end perforation but does not support segmented perforation. RTM supports segmented perforation and can also perform two vertical perforations on the right and left side of the printed output simultaneously.

Note the following:

- If you select one vertical perforation module in the vertical **Setup** list in the **Finisher Preset** window, you will have the option to use either PFM or RTM. However, if you select two vertical perforation modules in the vertical **Setup** list, you can use only RTM.
- If you select two vertical perforation modules in the vertical **Setup** list in the **Finisher Preset** window, you must specify settings for both vertical modules in the **Perforation** tab.

Specify vertical perforation

- 1 In **Module type**, select **PFM** or **RTM** depending on the type of job.
- 2 In **PFM L/R** or **RTM L/R**, select the type of perforation to be applied on the left and right side of the sheet.

Note: For RTM, after you specify perforations on the right and left, **No of vertical perforation** and **Segments** are automatically set to 1. You can change these values as required.

- 3 In **No of vertical perforation**, select the number of vertical perforations required by the job. When you select the number of vertical perforations, the Pattern definition settings are displayed.

Note the following:

- PFM supports only one continuous vertical perforation on the left and right side of the sheet.
 - For RTM, depending on the number of vertical perforations that you selected, corresponding rows of pattern definitions are displayed.
- 4 In **Pattern definition**, define the position of the vertical perforation. Positions of right and left perforations are calculated from the right edge of the finish size.

- In **X1R** and **X1L** settings, define the position of the perforation on the right and left side of the sheet.

Note: PFM supports only one vertical perforation.

- For RTM, specify the X position of each perforation on the right and left side of the sheet depending on the number of vertical perforations that you selected in **No of vertical perforation**.

For RTM, specify the following additional settings:

- **Segments** - Specify the number of segments required in the vertical perforation.
- **Position** - Specify the starting and ending position of each segment of the perforation. Position is calculated from the leading edge of the finish size. Depending on the number of segments selected, a corresponding number of position settings are displayed.

Note: Only RTM can perform segmented perforation.

Publish the finisher preset

- 1 After specifying settings to create the preset, you can apply the preset to the job and then publish the preset. Alternatively, you can simultaneously apply and publish the preset. In the **Finisher Preset** window, do one of the following:
 - Click **Apply** to apply the settings to the job. Then click **Publish** in the **Settings** pane.
 - Click **Apply & Publish** in the **Finisher Preset** window.

The **Publish layout** window opens.

- 2 In the **Publish layout** window, specify the following settings:
 - In **Finisher preset name**, specify a name for the preset.
 - **Finisher job number** displays the job number as specified in **Job/barcode number** in the **Finisher Preset** window. You can choose to auto generate a job number or specify a custom job number.
 - Select the **Save to finisher's job queue** check box to send the job directly to the job queue of the Duplo PC Controller computer.
Note: If you do not select this option, the preset is saved in the export folder. The Duplo PC Controller computer detects the new file, imports and validates the preset, and then adds the preset to its job queue.
 - Select the **Include thumbnail image** check box to include a thumbnail preview of the job when the job is listed in the job queue of Duplo PC Controller computer.

- 3 Click **Publish**.

Published presets are listed in the **Finisher Preset** list. You can apply published presets to different jobs that require the same layout and finishing settings.

Note the following:

- Diagnostic information, such as informational and warning messages, is displayed at the bottom of the **Settings** pane.
- You can select **Clear layout** in the **Settings** pane to remove the settings applied by the finisher preset.

Fiery Compose

Fiery Compose, allows you to prepare a spooled, held job in Command WorkStation for printing.

The available options for Fiery Compose depend on the printer you select. You can do any of the following in Fiery Compose:

- Set chapters and apply subset finishing, if supported
- Specify different media for front and back covers, body pages, and sections
- Insert blank pages, sheets, tabs, or other documents

The client computer must have an activated Fiery Compose license to use Fiery Compose.

Additional information

- You can work on any PDF or PostScript job at the page level. If you edit a PostScript job in Fiery Compose, Fiery Compose converts it to PDF. Any changes you make to the job appear in the Sheet View pane.
- If a job contains **Mixed Media** settings that were set in the printer driver or Command WorkStation, these settings appear when you view the job in Fiery Compose. After you save the job in Fiery Compose, you cannot go back and make changes in the **Mixed Media** window.

Setting job options before using Fiery Compose

You can set finishing options, such as stapling, folding, and punching, using Command WorkStation (in Job Properties), the printer driver, or Fiery Compose.

These methods can apply changes to an entire job. However, Fiery Compose can apply finishing options to subsets within the job. We recommend that you set subset finishing in Fiery Compose.

Open and view jobs in Fiery Compose

You use the Fiery Compose window to view jobs and make changes. The Fiery Compose window has three panes: **Page View**, **Sheet View**, and **Settings**.

- **Page View** - Displays the selected job as single-page thumbnails.
- **Sheet View** - Displays the entire job as thumbnails. You can toggle between thumbnail view and wireframe view. (Displaying thumbnails as wireframes speeds up performance.)

If the job is duplex, **Sheet View** displays the front and back of each sheet.

- **Settings** - Displays controls that affect the printing characteristics and layout on the final printing sheet surface. Which controls appear depend on the product intent.

Open a job in Fiery Compose



You can use Command WorkStation to open a spooled job in Fiery Compose.

- Select a spooled job in the **Held** list of Command WorkStation and open Fiery Compose in one of the following ways:
 - Select **Compose** from the Actions menu.
Right-click the job and select **Compose**.

Set the Sheet View to thumbnails or full pages in Fiery Compose

The **Sheet View** can switch between thumbnails and full-page view. You can also display thumbnails as wireframes.

Note: When you view a full page, the page size shown is the document bounding box, not the size of the media assigned to the page.

- Do any of the following:
 - Clicking the **Fit Page** icon () at the bottom of the window sets the zoom so that a single surface fits in the view area.
 - To switch the thumbnail view between thumbnails and wireframe views, click the **Toggle Sheet Content** icon ().

Adjust thumbnail size

The **Page View** pane lets you set thumbnail size. The **Sheet View** pane lets you zoom or specify percentage zoom.

- Do one of the following:
 - To enlarge or reduce thumbnails in **Page View**, click **View > Enlarge Thumbnails** or **View > Reduce Thumbnails**.
 - To zoom thumbnails in the **Sheet View**, drag the slider at the bottom of the **Sheet View** pane.

Work with pages in Fiery Compose

Fiery Compose allows you to add, rearrange, and delete pages, or insert pages from another job. You can also make page tabs, chapter starts, or covers; assign media to pages; and set duplex for selected pages.

Note: You should edit the job before you specify any mixed media settings. Editing a job can change page numbers, which can affect mixed media settings. Always check any mixed media settings after you edit a job.

Open a job for editing in Acrobat

Fiery Compose can open a job for editing in Adobe Acrobat Pro.

- Right-click a page in the **Page View** pane and then click **Edit in Acrobat**.

Reorder, delete, or set duplex for pages in Fiery Compose

You can manipulate selected pages in a Fiery Compose job.

- Do any of the following:
 - To reorder pages, click the page's thumbnail in the **Page View** pane and drag it to the new location.
 - To delete pages, select one or more pages and click **Edit > Delete**.
 - To apply duplex (if the printer supports it) to selected pages or chapters, select the pages, right-click them, click **Page Duplex**, and specify the setting that you want.

Note: To use duplex printing for an entire job, select the appropriate setting for the job in Command WorkStation before opening the job in Fiery Compose, or choose **Duplex** in the **Settings** pane.

Insert a blank sheet or page in Fiery Compose

Fiery Compose allows you insert blank sheets or pages anywhere in a document. Fiery Compose inserts the sheets or pages before the selected pages.

Implicit blank pages may be inserted automatically to accommodate chapter starts and duplex settings assigned to the original document. Because the implicit blank pages are not part of the original working document, you can choose to show the implicit blank pages or not.

- To show implicit blank pages, select **Show Implicit Blanks** from the **View** menu in Fiery Compose.

You can also manually insert blank pages.

- 1 Select a page in the **Page View** pane.
- 2 Do one of the following:
 - Select **Actions > Insert Blank Sheet**.
 - Select **Actions > Insert Blank Page**.

Assign media to pages in Fiery Compose

The **Sheet View** and **Page View** panes allow you to assign media to individual pages, or to ranges of pages. You can also assign media to an entire job in the **Page View** pane.

- 1 Select a page or pages.

- 2 Select **Assign Media** from the **Actions**.
- 3 Specify the media in the **Page/Page Range Media** window.

Convert to Grayscale

You can convert individual color pages or surfaces to grayscale.

Your job must contain color, and you must have an activated Fiery Compose or Fiery JobMaster license.

- 1 Import your job into the **Hold** queue of Command WorkStation.
- 2 Select the job in the **Held** list and select Fiery Compose or Fiery JobMaster.

You can also access the feature by opening Fiery Impose if it is activated and either Fiery Compose or Fiery JobMaster is also activated.

- 3 In either the **Page View** pane or the **Sheet View** pane, select a color page and either right-click, or go to the **Actions** menu, and select **Convert to Grayscale**.

The selected page or surface will be displayed as grayscale in the **Sheet View** pane. When that page is selected, the **Convert to Grayscale** option in the **Actions** menu has a check mark beside it.

- 4 To select multiple pages or surfaces in either **Page View** or **Sheet View**, do one of the following:
 - To select a consecutive group of pages or surfaces, click the first item, press and hold down the **Shift** key, and then click the last item.
 - To select nonconsecutive pages or surfaces, press and hold down the **Ctrl** key, and then click each item that you want to select.

You can revert groups or individual pages or surfaces to color by selecting and choosing **Convert to Grayscale** from the **Actions** menu, even if they were selected as part of a group. The check mark is then removed.

Note: Actual conversion of the pages or surfaces occurs when the job is saved. If you modify the job after it is saved, any modifications that involve adding color will not be converted to grayscale.

Work with chapter starts in Fiery Compose

To divide a document into chapters, you can mark the start of each chapter in the **Page View** pane, and then apply finishing options in the **Settings** pane. You can also remove a chapter start mark.

A chapter start page is printed on the front side of a sheet. In a reader's spread, a chapter start pages are on the right. Green check marks in the **Page View** pane indicate chapter start pages.

- Do any of the following:
 - To add a chapter start, select a page that has no chapter start mark and click **Actions > Chapter Start**.
 - To remove a chapter start, select a page that has a chapter start mark and click **Actions > Chapter Start**.
 - To show the blank pages that Fiery Compose inserts before chapter start pages, click **View > Show Implicit Blanks**.

Set tabs in Fiery Compose

You can add a tab page anywhere in the document and select the tab media. All tabs in a job must use the same media, even if multiple tab media are available.

You can add one or more tabs in the **Page View** pane. When tabs have been added to a document, you can use the **Filter Tabs** icon in the **Page View** tool bar to display only those pages with tabs.

- 1 Select the page or pages before where the tab should be.
- 2 Click **Actions > Insert Tab** or right-click and select **Insert Tab**.

A tab using the default tab media is added before the selected page. If a tab already exists in the job, new tabs must use the same media as the existing tab.

- 3 To specify different media for the tab, right-click and select **Edit Tab**.
Changing the media for one tab changes it for all tabs in the job.

Note: In Fiery JobMaster, you can add multiple media for tabs in one job. See [Add multiple tab styles to a document](#) on page 114.

Set tab text and other properties in Fiery Compose

You use the **Edit Tab** window to set tab text and position properties, and the tab media.

- 1 Select the tab page.
- 2 Right-click the selected tab page and then click **Edit Tab**.
- 3 Type the desired text in the **Text** field.
- 4 Use menus and buttons below the **Text** field to specify text attributes such as font, size, alignment, and text rotation.
- 5 To apply the same text settings to all tabs, click **Apply styles to all**.

Set up covers

Fiery Compose lets you set up the front and back covers of the document independently and choose their media from the Media Catalog or Paper Catalog. You can use the document's front and back pages as the front and back covers, or you can insert covers.

- 1 In the **Settings** pane, click **Cover > Define**.
- 2 Do one of the following in the **Cover Media** window:
 - To apply the same settings to the front and back cover, click **Apply the same setting for both front and back cover**.
 - To set up the front cover and back cover separately, select **Front Cover** or **Back Cover**.
- 3 Specify the settings.

Subset finishing in Fiery Compose

If the printer supports it, you can apply individual finishing options to subsets in the job, thus applying a variety of finishing options in one pass. You can define subsets according to chapters, sheet ranges, or a custom range.

First, you should specify finishing options for the whole job, including media and setting duplex if desired. For details, see [Set sheet size in Fiery Impose](#) on page 54 and [Duplex settings in Fiery Impose](#) on page 54.

You then create subsets within the job, and then specify finishing options and set media for individual subsets, ranges of sheets or pages, or individual sheets or pages.

Subset finishing rules

- Sheets in a subset must be continuous, including any inserts or tabs added in Fiery Compose.
- You use the **Page View** pane to define chapter starts for chapter subset finishing.
- The **Settings** pane specifies the sheet count for sheet subset finishing. Each subset contains the same number of sheets.
- The **Sheet View** pane defines custom subsets. Each subset can be of any length.
- If you switch the **Set Definition** from chapter or number of sheets to custom, the previously defined subsets are the starting point for the **Custom** settings.
- Switching the **Set Definition** from custom to chapter or number of sheets removes the custom subsets and replaces them with the new definition.
- All sheets within a subset must be of the same size, except for tabs and Z-fold inserts.
- You cannot specify covers for finishing subsets.
- If you define subsets for a single-sided or simplex job, and then specify duplex for the job, note that:
 - For sheet subset finishing, the subsets maintain the sheet count. For example, a subset that was 3 pages on 3 sheets remains as 3 sheets, but with 6 pages.
 - For chapter and custom subset finishing, the subsets maintain the page count, adding blanks as necessary to fulfill the duplex requirement.

Specify a set definition in Fiery Compose

You specify subset finishing by specifying the **Set Definition** in the **Settings** pane, and then applying finishing options.

- 1 In the **Settings** pane, click one of the following in the **Set Definition** menu:
 - **Custom** - Defines subsets by selecting different ranges of sheets as desired in the **Sheet View** pane.
 - **Chapters** - Specifies chapter starts to create subsets.
 - **Number of sheets** - Specifies a fixed number of sheets to a subset, so that each subset consists of the same number of sheets.
- 2 Click **OK**.

Apply subset finishing in Fiery Compose

You can apply chapter, sheet, or custom subset finishing.

To apply chapter subset finishing, specify chapter starts and then set finishing and media for the chapter subsets. The Sheet View pane displays the job divided into the chapter subsets.

To apply sheet subset finishing, specify how many sheets are in a subset. Fiery Compose then divides the job into subsets of equal length.

Custom subset finishing provides full control of the length of subsets. You specify subsets in the **Sheet View** pane. Each custom subset can contain a different number of sheets.

- 1 In the **Settings** Pane, click options in **Fold**, **Hole-Punch**, and **Stapling** menus.
- 2 If you are applying chapter subset finishing, do the following:
 - a) Select a chapter start page in the **Page View** pane and click **Actions > Chapter Start**.
 - b) In the **Settings** pane, click **Chapters** in the **Set Definition** menu.
- 3 Assign global media, if desired.
- 4 If you want subsets of equal length (sheet subsets), select **Number of Sheets** from the **Set Definition** menu in the **Settings** pane. Then type the number of sheets you want in a subset.
- 5 If you are applying custom subset finishing, do the following:
 - a) In the **Settings** pane, click **Custom** in the **Set Definition** menu.
 - b) In the **Sheet View** pane, select the beginning sheet of a subset, right-click, and click **Create Subset**. Repeat for each subset.
- 6 Remove unwanted finishing options from individual subsets.
- 7 To assign media, do one of the following:
 - To assign media to individual subsets, right-click the subset header and select **Assign Media**.
 - To assign media to individual sheets or a range of sheets within a subset, select the sheets, right-click, and select **Assign Media**.
- 8 To perform other functions on the subset, right-click the header bar and choose from the menu.
- 9 To remove a subset, select it, right-click, and then select **Remove Subset**.

Specify subset finishing for Z-fold in Fiery Compose

If your printer supports Z-fold finishing, you can specify Z-fold for individual sheets in a subset.

The Z-fold insert is twice the size of the subset body paper, and both must be standard sizes that the printer and the folding finisher support. Custom sizes are unsupported. The feed edge of both the body paper and the Z-fold insert must be the same size.

For example, if you have a Letter size job, the Z-fold insert will be 11x17, short-edge feed. If your job is A4, the Z-fold insert will be A3, short edge feed.

- 1 In the **Settings** pane, click **Z-fold** in the **Fold** menu.
- 2 In the **Sheet View** pane, select a sheet, right-click and then click **Z-fold**.

Save a job in Fiery Compose

If you make changes to a job in Fiery Compose, you must save it before you print it.

In Fiery Compose, a flattened PDF does not include blank sheets and implicit blank pages, and tab pages lose their tab media assignment. When you save a job, the save window remembers where you saved it, and uses this location the next time you save a job.

- 1 Select **Save** from the **File** menu.
- 2 Type the file name in the **Save as** field.
- 3 Choose the location to save the file in the **Where** menu.
- 4 Click **OK**.

Fiery JobMaster

Fiery JobMaster is an advanced PDF-based job-preparation solution designed to help operators perform complex document tasks and late-stage editing.

In addition to Fiery Compose options, you can do any of the following in Fiery JobMaster:

- Create tabs based on PDF bookmarks
- Scan jobs and apply edits
- Apply advanced page numbering for specified sections

The client computer must have an activated Fiery JobMaster license to use Fiery JobMaster.

Job Summary in Fiery JobMaster

The **Job Summary** pane in the Fiery JobMaster window provides an interface for easy selection and filtering of pages.

Job Summary is located below the **Page View** pane. If it is not displayed when you open a job in Fiery JobMaster, click the double arrows in the **Job Summary** title bar.

Note: The **Job Summary** pane is only available if Fiery JobMaster has been activated.

Job Summary displays all page attributes that can be used for filtering or selecting certain groups of pages in the **Page View** pane. The list includes only attributes that are currently used in the job and is updated every time changes are made to the job.

Page properties, or attributes, may include any of the following:

- **Page Size**
- **Media Size**
- **Media Type**
- **Page Type**
- **Media Weight**
- **Media Color**
- **Page Orientation**
- **Page Duplex**

Note: This filter applies only to page level duplexing. It does not reflect the duplex setting in the **Settings** pane. The options displayed are dependent on the job properties/printer driver options available for your Fiery server.

- **Convert to Grayscale**

- **Chapter Starts**

Note: Chapter starts may have been added automatically at the first page of an inserted PDF job. See [Adding chapter starts automatically](#) on page 15.

- **Bookmarks**

Filter pages in the Job Summary pane

You can filter and select sections of long jobs in the **Job Summary** pane.

- 1 Select a spooled, unprocessed job in Command WorkStation **Held** list.
 - Right-click the job and select **JobMaster**.
 - In the **Actions** menu, select **JobMaster**.
 - Click the **JobMaster** icon in the **Job Center** toolbar.

When the **Fiery JobMaster** window opens, if the **Job Summary** pane is not displayed, click the arrows in the **Job Summary** title bar below the **Page View** pane.



- 2 To sort and view pages by a specific attribute, clear all other check boxes.
For example, to view odd-numbered pages, keep the **Page Type > Odd pages** check box selected.
Note: The display in **Page View** changes; the display in **Sheet View** does not.
- 3 Click the hyperlinked name of an attribute to display all the pages with that attribute.
The pages are selected in **Page View**, and all previous selections are cleared.
- 4 To synchronize the selection in **Page View** to **Sheet View**, left-click a selected page in **Page View**.
To synchronize the selection in **Sheet View** to **Page View**, you can use **alt+left-click** on a Windows computer keyboard or **option+left-click** on a macOS computer keyboard.
- 5 Click the **Clear Filter** icon in the **Job Summary** title bar to select all check boxes and remove any filters.

You can also select ranges of pages with **Edit > Select Pages by Range**. You can use the **Select Invert** command in the **Edit** menu to toggle the selection in **Page View**. All selected pages become unselected, and unselected pages become selected.

Select Pages by Range

The **Select Pages by Range** option is available in the main **Fiery JobMaster** window and in the **Numbering and Stamps** pane.

This feature can be used in combination with the filtering options in the **Job Summary** pane. Selections made in the **Fiery JobMaster** window apply in the **Numbering and Stamps** pane, which you open by selecting **Edit Numbering and Stamps** from the **Actions** menu.

- 1 Select a spooled, unprocessed job in Command WorkStation **Held** list.
 - Right-click the job and select **JobMaster**.
 - In the **Actions** menu, select **JobMaster**.
 - Click the **JobMaster** icon in the **Job Center** toolbar, if it has been added.
- 2 Do one one of the following:
 - Click **Select Pages by Range** in the **Edit** menu in the **Fiery JobMaster** window. Type a range using a hyphen to specify a range, and commas to separate individual numbers, or ranges (for example, 1-9). Alternatively, select the **Repeat** radio button and enter the required information.

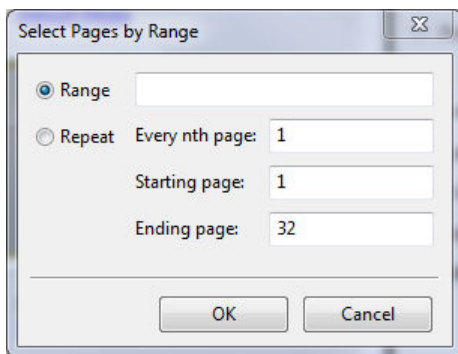

- Select a range of pages by using the filtering options in the **Job Summary** pane. For example, select the **Odd Pages** check box. Click **Select Pages by Range** in the **Edit** menu.

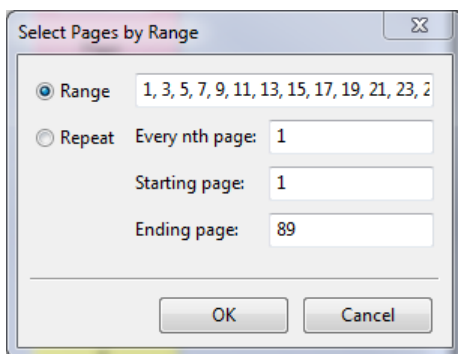

If you open the **Numbering and Stamps** pane, the selected page range will be displayed. You can add more ranges in the **Numbering and Stamps** pane.

Shift the content of a page or pages

Page Offset lets you easily move page content to accommodate finishing requirements. For example, you can quickly shift the page content of all your odd pages to the right and your even pages to the left to accommodate staples. You can also move the content of scanned pages by a small amount from the spine of a booklet.

- 1 In Command WorkStation, open a spooled file with Fiery JobMaster.
- 2 In the **Page View**, select the page or pages for which you want to shift the page content.
- 3 Select **Actions > Edit Page**.
- 4 Set the **x** and **y** values.
Positive **x** values move the page content to the right; negative values move it to the left. Positive **y** values move the page content up; negative values move it down.

The **x** and **y** values are reset to zero when you reopen the **Edit Page** window.

You can also shift the content of the page in the **Scale Content** pane. For more information, see [Open the Scale Content pane](#) on page 97

Open the Scale Content pane

In the **Scale Content** pane, you can scale the content on individual pages or page ranges.

- 1 In the **Page View** pane, select the page or pages you want to scale.
You can select an individual page or select a page range provided in the **Job Summary** pane. You can also select all the pages in the **Page View** pane.
- 2 Select **Actions > Scale Content**.
Note: If the page range contains duplicate pages, a message will appear. Click **Yes** to resolve the page range conflict.
- 3 (Optional) Select pages in the **Page View** pane and click **Add Selected Pages** in the **Scale Content** pane to add more page ranges.
The added pages will appear in the **Page Range** list.
- 4 To edit a page range, do one of the following:
 - Right-click a page range in the list and select **Update Selected Pages**.
 - Double-click a page range in the list.
- 5 To save and apply all your changes, click **OK** in the lower-right corner in the pane.

Page-level options in the Scale Content pane

When the **Scale Content** pane is open, you can scale, size, and position content on a page or a page range.

You can specify settings in the **Scale Content** pane using the following controls:

Item	Description
<p>Finish size</p>	<p>Select the size of the paper required for the page from the Finish size list.</p>
<p>Orientation</p>	<p>Select Portrait to arrange pages in portrait orientation or select Landscape to arrange pages in landscape orientation.</p>
<p>Bleed for all sides</p>	<p>Type the size of the bleed for the pages.</p>
<p>Rotation</p>	<p>Select the angle, in degrees, to rotate the content of a pages as specified by one of the settings.</p> <p>You can select from the following:</p> <ul style="list-style-type: none"> • 0 • 90 • 180 • 270 • Auto Clockwise 90 • Auto Counterclockwise 90 <p>Note the following:</p> <ul style="list-style-type: none"> • If 0 is selected, no rotation will be applied. • You can apply automatic page rotation when the individual page orientation is different from the specified Orientation setting.
<p>Scale factor</p>	<p>Select the Scale factor to adjust the size of your content on the page.</p> <p>You can select from the following:</p> <ul style="list-style-type: none"> • Fit to finish size • Fill to finish size • Fit to imageable size • Fill to imageable size • Fit to bleed size • Fill to bleed size • Custom <p>Note: When Custom is selected, you can type values for the Width and Height manually in the fields that appear. The aspect ratio of the original document is preserved when values are entered.</p>

Item	Description
Align content to	Select one of the following to define how the content should be aligned on the page: <ul style="list-style-type: none"> • Finish size • Imageable size
Alignment	Select a vertical alignment icon and a horizontal alignment icon to align the content on the page. The Alignment option determines the initial position of the content on the page.
Offset	Type the Offset settings in the X and Y axis fields. The Offset settings can be used to further adjust the content after specifying Alignment options.

Optionally, you can save your settings as a preset by clicking the **Save Preset** icon and naming the preset.

Inserting image files into Fiery JobMaster

With **Insert Image Files**, you can add these file types to a job: BMP, GIF, JPEG, JPG, PNG, TIF, and TIFF.

You can add multiple image files at a time.

Note the following:





- Multi-page TIFF files are not supported on macOS.
- JBIG compressed images embedded in scanned TIFF files are not supported.

Edit a scan in Fiery JobMaster

By default, when you insert a PDF document into Fiery JobMaster, the document is checked for scanned content. If scanned content is found, you will be asked whether you would like to review and edit the scanned images. You can then adjust aspects of the scan, such as size, brightness, and despeckling.

You can use the functions in the **Scan Preview & Edit** window during the scan operation and when scanned content is being imported into a Fiery JobMaster job. You cannot apply these functions to pages that are already part of a Fiery JobMaster-Fiery Impose job.

- 1 Right-click a held job in Command WorkStation **Job Center**, and select **JobMaster**.
- 2 In the **Fiery JobMaster** window, select **Insert > Insert From Scanner** or **Insert > Insert Image Files**.
 If the inserted pages contain scanned content, you will be asked whether you would like to review and edit the scanned images.
- 3 To edit the scan, use the options in the scan **Preview & Edit** window. These options are available on a per page basis, or if the **Apply to All** button is selected, to all pages in the scan job.

- **Acquire**  - Acquires the scan from either the mailbox or the scanner. This option is available only if you are using **Insert From Scanner**.
- **Select** , **Move**  - Selects or moves the scanned image in the viewer.
- **Zoom**  - Zooms in and out. Click the icon to fit the scanned page to the preview window.
- **Deskew** - Straightens an image.
- **Despeckle** - Removes tiny dots or specks that sometimes appear on scanned images.
- **Media Size** - Automatically applies the nearest page size from the page size list to the scanned page, rotated as necessary. For example, 8.48 x 10.98in would result in 8.5 x 11in portrait and if the image is rotated, 8.5 x 11in landscape.

Note: Scan Size sets the final page size to the original scan size. Page Size defines the imported document page size. The scanned image will be resized to that page size. The page sizes listed are determined by the printer driver.

- **Width, Height** - Determined by the selections in **Media Size** and **Orientation**.
- **Delete this page**  - Deletes the selected page in the preview window.

Note: Additional pages can also be scanned and added to the existing scan job.





4 Click **Import**.

- 5 In the **Insert Pages** window, select scanned pages and drag them onto the **Page View** pane in the **Fiery JobMaster** window.

Edit a page in Fiery JobMaster

With Fiery JobMaster, you can edit pages of a job for finishing by rotating, masking, and cropping. You can specify changes according to either crop box or trim box finish size.

- 1 Right-click a spooled job in Command WorkStation, and choose **JobMaster**.
- 2 In the **Page View** pane, select the page or pages you want to edit and choose **Actions > Edit Page**.
The **Edit Page** window displays measurement markers on the left and top of the window.
- 3 Specify the settings.

- **Panning**  - moves the PDF page in the preview window.
- **Mask**  - masks one or more areas of the page. Click and then draw the area to be masked. Applies the same masked areas to all of the selected pages before opening the **Edit Page** window. Overrides masks previously made on any of these pages.
- **Zoom**  - zooms in. To zoom out, click the Fit-to-Image icon.
- **Rotate**  - rotates the page in 90-degree increments.

- **Mode - Margin** lets you adjust the existing crop box or trim box. By applying a margin, you can define how much smaller (or larger) the new crop box or trim box will be than the original one. **Size And Offset** lets you define an entirely new size for the crop box or trim box, and can position the new crop/trim size directly against the existing content. If you select **Mode - Margin** or **Mode - Size And Offset**, and then enable Crop Box, you can change **Predefined Crop Size**. **Mirror** aligns the contents of odd and even pages with the duplex option. The default setting for **Mode** is **Page Offset**, which allows you to shift the content of a page by entering positive or negative values in the X and Y fields.
- **Crop Box, Trim Box** - these are available only when **Margin** or **Size and Offset** is selected. To edit either, click the adjacent button.

4 Do one of the following:

- Click **OK** to save the settings.
- Click the **Reset** button to restore the original settings.
- Click **Cancel** to exit.

For more information about the settings, see [Edit Page workflow](#) on page 101.

Edit Page workflow

The **Edit Page** feature gives the user the ability to move content on a selected page or pages to avoid cut-off of page content when stapling or hole-punch type of finishing is applied.

Edit Page can be used to crop or move content on a page or pages by adjusting the page **Crop Box** or **Trim Box** size.

Page Offset

Page Offset is the easiest way to move page content and is the default mode in **Edit Page**. **Page Offset** simultaneously adjusts both the crop box and the trim box in a way that complies with PDF rules about the sizes of these boxes.

Use the **X** and **Y** controls to shift the page content.

Crop Box and Trim Box

To enable either **Crop Box** or **Trim Box**, click the toggle button so that it appears green.

Enabled: 

Disabled: 

Select **Margin** or **Size And Offset** to make **Crop Box** and/or **Trim Box** adjustments.

The **Crop Box** defines the region to which the page contents are to be clipped. Acrobat uses this size for screen display and printing. The **Trim Box** defines the intended dimensions of the finished page. For most documents, by default, the crop box and trim box are equal in size.

When you enable either, Fiery JobMaster reads the crop box and trim box information from the file. The crop box frame is indicated by a line of dashes. The trim box frame is indicated by a line of dashes and dots.

Margin

In the example below, content on page 4 needs to be moved to the right to allow a hole-punch on the left of the page. **Trim Box** is adjusted to move the left margin further to the left with a -0.5 in. value and move the right margin to the left with a 0.5 in. value. These adjustments effectively push the page content to the right and create more blank space for the hole-punch on the left side of the page.

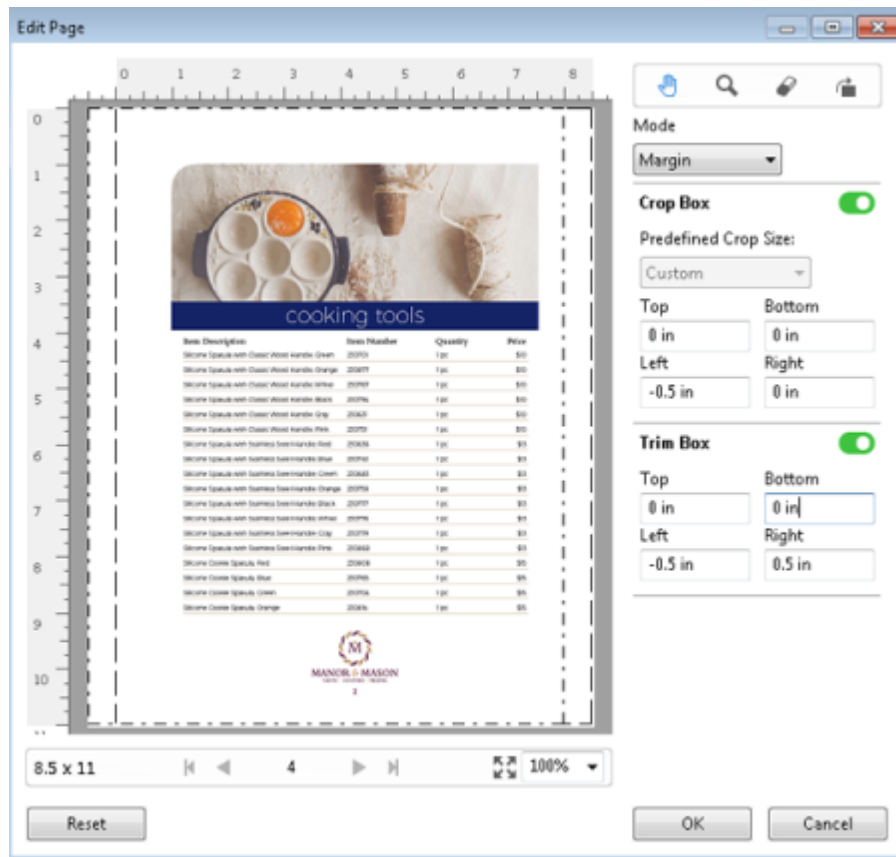

Size And Offset

When **Crop Box** has been enabled, **Size And Offset** gives the ability to customize **Crop Box** by either selecting a standard sheet size or specifying the **Width** and **Height** of **Crop Box**. **Left** and **Top** are used to specify the distance between the left side and the top of **Trim Box** in relation to the **Crop Box**. When **Trim Box** has been enabled, the page's **Trim Box** can be customized by specifying **Width** and **Height**.

In the example below, **Crop Box** and **Trim Box** initially have the same size, 8.5 in. by 11 in. With 0.5 in. left offset for **Crop Box**, the **Crop Box** is moved to the right by 0.5 in. Because **Trim Box** stayed in the same position, the **Trim Box** is reduced by 0.5 in. on the left and is now 8 in. by 11 in.

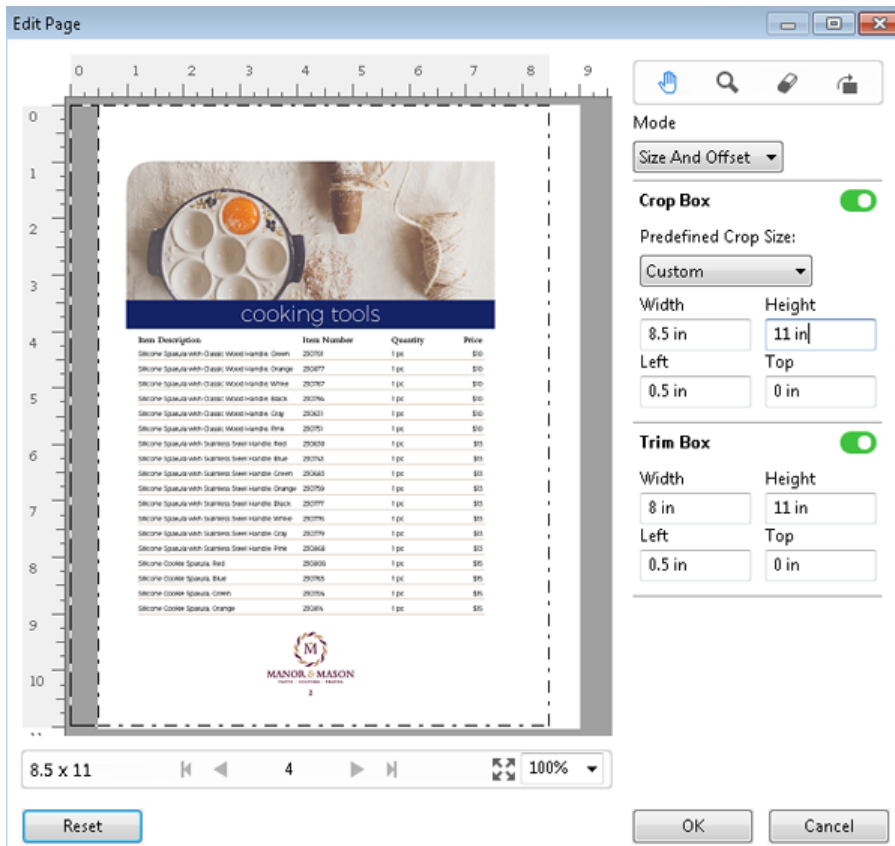

For a job that requires hole-punch finishing on the top edge, the user has entered a negative value in the **Top** field for **Trim Box** (see example below). The **Trim Box** size is maintained, but the content has been moved down, providing more space for the hole-punch. Note that the **Predefined Crop Size** option is not enabled, but the user can change the values in the **Width** and **Height** fields.

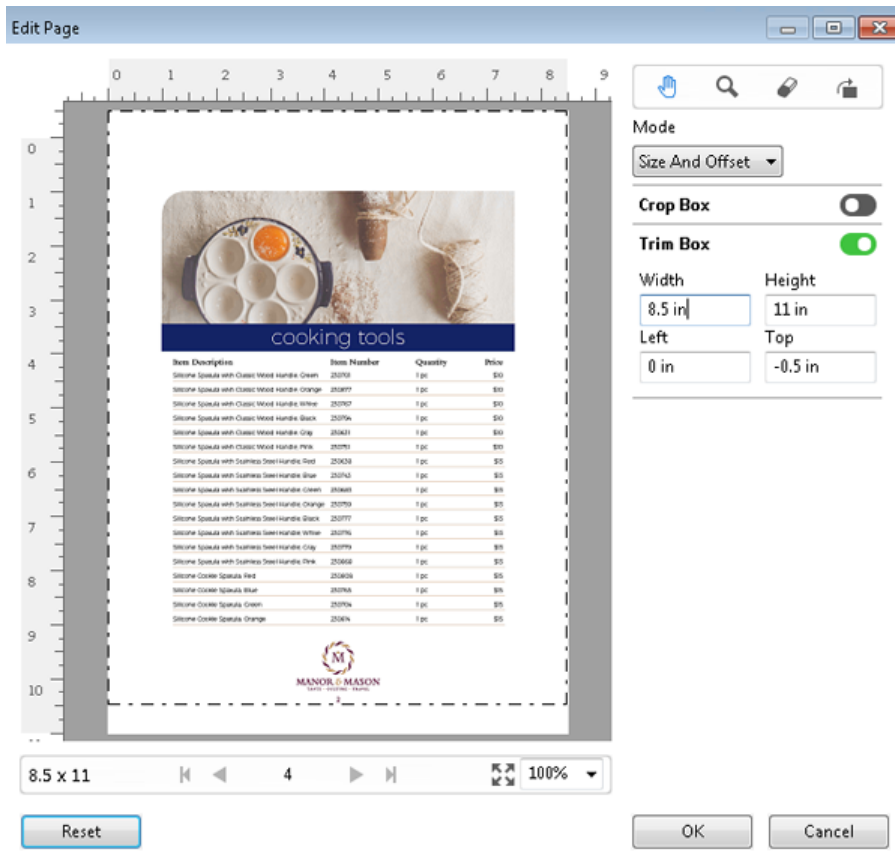

NCR multi-part pad printing workflow

Multi-part pad printing is used for such jobs as multi-part invoices or order forms, or raffle tickets.

Fiery JobMaster provides options to create a NCR (No Carbon Required) multi-part pad printing workflow. Forms or pads can be made up of multiple parts, usually two to four parts, and mixed duplex and simplex. For example, a three-part form may have the first two parts with texts on both sides of the sheet and the third part with text only on the front side.

A possible workflow would incorporate the following steps:

- Begin with a job that includes all pages necessary to make one set.
- If the job starts with one page, you can duplicate the page by applying **Duplicate** from the **Edit** menu to create as many copies as you need to make one set.
- Designate which media or tray is required for each page/sheet.
- Apply **Duplicate Job** from the **Edit** menu to create the number of total sets required.
- Apply advanced numbering to custom stamp the pages and sets.
- Apply layout using Fiery Impose.

Features that make this workflow possible are:

- **Duplicate** and **Duplicate Job** in the **Edit** menu
Duplicate duplicates a form or a part one at a time. To create multiple copies, you have to apply the **Duplicate** function repeatedly. **Duplicate Job** duplicates the job as many times as you specify in the **Duplicate Job** window.
- Repeat numbering in the advanced page numbering workflow
 You can achieve this through the **Select Pages by Range** window and the additional page range options available in the **Numbering and Stamps** pane. An example is **Numbering options > Use custom numbering for this range > Times to repeat**.

Advanced Page Numbering and Stamping

Advanced page numbering allows you to add custom numbering and stamps to sections of a job, such as a range of pages or specific chapters.

You can specify different styles for different sections of your document, for instance, roman numerals for front matter and appendices, and Arabic numerals for the body of the document. Alternatively, you can designate pages that have no page number printed, but are included in the counts.

Some possible uses of the advanced page numbering feature are described in the following examples:

- In a five-page job where each page is counted, the pages are numbered (1, 2, 3, 4, 5).
- In a five-page job where each page is counted and the starting number is 10, the pages are numbered (10, 11, 12, 13, 14).
- In a five-page job where each page is counted and the increment value is 2, the pages are numbered (1, 3, 5, 7, 9).
- In a five-page job where only the last page is counted, the pages are numbered (x, x, x, x, 1) where "x" indicates a page with no number printed on it.
- In a five-page job where the first two pages are skipped, the pages are numbered (x, x, 3, 4, 5) where "x" indicates a page with no number printed on it.
- In a ten-page job set up as chapters, with two pages in each chapter (five total chapters), the pages are numbered ([1, 2], [1, 2], [1, 2], [1, 2], [1, 2]) where [] shows each chapter.
- In a NCR multi-part pad, all the pages in one set are numbered the same (1, 1, 1, 2, 2, 2, 3, 3, 3), where a set consists of three parts.

For information about the controls available for the advanced page numbering feature and how to use them, see [Advanced page numbering workspace](#) on page 106 and [Set Advanced Page Numbering options](#) on page 108.

Type and Range

You can add a range of pages or chapters, or the whole document to make advanced page numbering options available. The **Type** and **Range** panes contain the following possible settings:

Type	Range
Page	Page numbers, or page ranges, separated by commas
Document	All pages
Chapter	Chapter numbers, or chapter ranges, separated by commas

Numbering properties

You can add the numbering properties for each of the ranges. The available options are the following:



Element	Options	Format
Page	<ul style="list-style-type: none"> Current Page Total Pages Page {current} Page {current} of {total} Page {current}/{total} {current} of {total} {current}/{total} 	Multiple formats: 1,2,3 a,b,c A,B,C i,ii,iii I,II,III
Chapter	<ul style="list-style-type: none"> Current Page Total Pages Current Chapter Total Chapters 	Multiple formats: 1,2,3 a,b,c A,B,C i,ii,iii I,II,III
Document	Name	
Date & Time	<ul style="list-style-type: none"> Date Time Date & Time Date Formats Time Formats Date Specifiers Time Specifiers 	Multiple formats

Advanced page numbering workspace

The **Numbering and Stamps** pane provides a workspace for advanced page numbering.

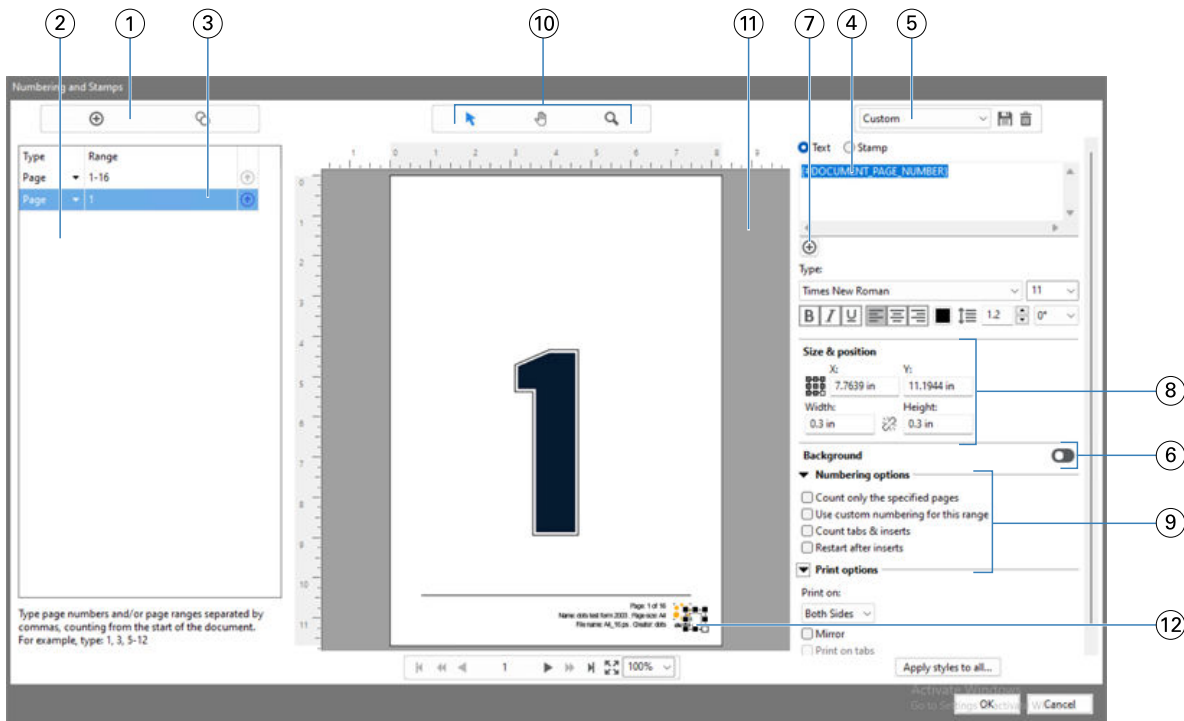
In Fiery JobMaster, you can access the **Numbering and Stamps** pane by selecting a page or pages in the **Page View** pane, and then selecting **Actions > Edit Numbering and Stamps**.



- 1 **Add Range** and **Copy Range** icons for adding ranges, and copying a range.
- 2 **Type** and **Range** panes displays added ranges for document, chapters, and pages.
- 3 Click the second set of ellipses to open a window that allows you to specify **Range** and **Repeat** options.
- 4 **Presets** menu, and **Save Preset** and **Delete Preset** icons.
- 5
Text field displays macros for the numbering options you specify from clicking the plus sign icon () below the text field. You can add text to the macros.
- 6 Controls for enabling and disabling a background for the page number field in the document.
- 7
The plus sign icon () opens menus for specifying page numbers, chapter numbers, date, time, and the name of the document.
- 8 Under **Size & position**, you can input **X**, **Y**, **Width**, and **Height** information.
- 9 Advanced numbering and printing options.
- 10 **Select**, **Move**, and **Zoom** icons for the preview pane.
- 11 Preview of the job. The navigation and zoom controls provided below the preview.
- 12 Field for page numbering display, can be resized and moved.

Add a page range

You can add a page or range of pages to the **Numbering and Stamps** pane.

- 1 Right-click a spooled job in Command WorkStation, and choose **JobMaster**.
- 2 In the **Page View** pane, select a page or pages, and choose **Actions > Edit Numbering and Stamps**.

3 Add a page or page range range in one of the following ways:

- In the **Numbering and Stamps** pane, click the **Add Range** icon (⊕) above the **Type** and **Range** panes. Choose a type of range from the **Type** menu. Enter a range in the **Range** field.
- In the **Page View** pane, select a page or a page range. Right-click your selection and select **Add Selected Pages**.
- In the **Job Summary** pane, clear any check boxes to filter the page ranges by your desired attributes. Right-click the selected page or pages and select **Add Selected Pages**. For more information on filtering the **Job Summary** pane, see [Filter pages in the Job Summary pane](#) on page 94.



Edit a page range

You can edit a page or range of pages to the **Numbering and Stamps** pane.

- 1** Right-click a spooled job in Command WorkStation, and choose **JobMaster**.
- 2** In the **Page View** pane, select a page or pages, and choose **Actions > Edit Numbering and Stamps**.
- 3** To edit a page range, do one of the following:
 - Select a page range in the list in the **Numbering and Stamps** pane and then select a page or range of pages in the Page View pane. Right-click your selection and select **Update Selected Pages**.
 - Double-click a page range in the list and type a new page range.

Set Advanced Page Numbering options

- 1** Right-click a spooled job in Command WorkStation, and choose **JobMaster**.
- 2** In the **Page View** pane, select a page or pages, and choose **Actions > Edit Numbering and Stamps**.

Note: If you want to add chapter starts to the job, do so before selecting **Edit Numbering and Stamps**.
- 3** Add a page or page range range in one of the following ways:
 - In the **Numbering and Stamps** pane, click the **Add Range** icon (⊕) above the **Type** and **Range** panes. Choose a type of range from the **Type** menu. Enter a range in the **Range** field.
 - In the **Page View** pane, select a page or a page range. Right-click your selection and select **Add Selected Pages**.
 - In the **Job Summary** pane, clear any check boxes to filter the page ranges by your desired attributes. Right-click the selected page or pages and select **Add Selected Pages**. For more information on filtering the **Job Summary** pane, see [Filter pages in the Job Summary pane](#) on page 94.
- 4** To duplicate a range, select it and click .
- 5** To move a range up in the list, click .
- 6** To delete a range, click .

7 To open the **Select Pages by Range** window, click the ellipses in the **Range** field. For more information, see [Select Pages by Range](#) on page 96.

For information about the possible settings, see [Type and Range](#) on page 105.

8 To add numbering properties, click  below the **Text** field.

For information about the possible settings, see [Numbering properties](#) on page 106.

The numbering choices are displayed on the page in the preview pane, and the macro, or macros, are displayed in the **Text** field.

9 To change the size of the page number field and to move it to another location on the page, use the **Select** icon () at the top of the preview pane.

The **Move** icon () moves the image in the preview pane when zoomed in.

10 To customize the numbering properties that you have selected, you can make changes in the **Text** field.

Note: If you add multiple numbering elements to a range, for instance, page numbers, chapter numbers, and date or time, macros are added to the **Text** field in the order that you selected the elements from the menu, without spaces between the macros.

- To add spaces between the numbering elements, insert spaces between the macros.
- To create multiple lines in the page number display, use the **Enter** or **Return** key to insert a carriage return between macros.
- To remove a numbering element choice, delete the macro in the **Text** field.
- To add some static text to the numbering element, type the text where you want it to be in relation to the macro or macros.
- To pad a page number with zeroes, asterisks, or spaces, enter the padding character, followed by a numeral indicating how many characters the page number should be, followed by a colon. For example, to add zeroes to pad the number to 7 characters, modify the page number text in the following way: `{#07:DOCUMENT_PAGE_NUMBER}`. If the page number was 6, the resulting output would be: "0000006".

11 To add a background to the number field, click . Select color and opacity of the background for the page number field.

The icon changes to .

12 Choose **Type** settings, such as font, color, size, style, angle.

13 Choose from one of the following **Numbering options**:

- **Count only the specified pages** - Select this to indicate that only the pages in the selected range are counted.
- **Use custom numbering for this range** -
 - **Pages to skip** - If a page is skipped, the page will be included in the count, but will not show a page number.
 - **Start #** - The document is numbered starting with the number you enter. If you selected the option to count only the specified pages in the range, the section is numbered starting with the number you entered.

- **Increment** - For each page in the document or range, the page number will increment from the previous page by the value you enter.
- **Times to repeat** - Specify how many times to repeat the page number in the range.
- **Count tabs & inserts** - Includes inserted tabs or blank pages when calculating the page numbers.
- **Restart after inserts** - Restarts the page numbering after an insert, according to the starting page number you have set.

14 Choose from one of the following **Print options**:

- **Print on** - Print the page numbering on both pages, the front only, or the back only.
- **Mirror** - Positions page numbers in mirror image on facing pages.
- **Print on tabs** - Prints the page numbers on the inserted tabs, if you selected **Count tabs & inserts** in the **Numbering options**.
- **Apply styles to all** - Select the styles you want applied to all the ranges.

15 Click **OK**.

You can preview the page numbering in the **Sheet View** pane in the **Fiery JobMaster** window. You can also save the settings as a preset to the presets menu. For information about presets, see *Fiery Command WorkStation Help*.

Add an image stamp

You can add an image stamp to a page, chapter or range of pages, or to the entire document.

1 Right-click a sheet in Fiery JobMaster, and select **Edit Numbering and Stamps**.

2 Click the plus icon (**Add Range**) in the left-hand pane.

A center pane opens.

3 Click the button next to **Stamp**.

4 Click **Browse** to browse to the location of the image you want to use for the stamp.

5 In the center pane, under **Size & position**, **X** and **Y** specify the position of the stamp (coordinates of the anchor point), and **Width** and **Height** specify the size of the stamp.

You can lock the aspect ratio of the stamp by clicking the link icon between **Width** and **Height**. When the aspect ratio is locked, click the link icon to unlock the aspect ratio.

6 In the left pane, under **Type**, you can apply the stamp to a page or range of pages (by using a dash; for example, 2-3), to a chapter, or to the entire document.

Resize and reposition the stamp

In the center pane, under **Size & position**, the square icon (composed of nine smaller squares) lets you resize and reposition the stamp.

- To resize the stamp, do one of the following:
 - Click a corner square to drag the corner to resize the stamp.
 - Click a side square to drag the side to resize.
 - Click the center square to drag the stamp around by its center.

Set the print options for the stamp

- Print options for the stamp are the following:
 - For the **Print on** option, select **Both Sides**, **Front Only**, or **Back Only**. **Both Sides** prints the stamp on each side of the sheet. **Front Only** prints the stamp only on the front side of the sheet. **Back Only** prints the stamp only on the back side of the sheet.
 - Selecting **Mirror** causes the stamp's position on the page to be mirrored on the back side of sheets.
 - Selecting **Print on tabs** prints the stamp on the tab pages.

Set the background color for the stamp and adjust the opacity of the background color

- To set the background color for the stamp and adjust the opacity of the background color, do the following:
 - Under **Background**, click the toggle button to open the background color and opacity controls.
 - Use the **Color** option to select the background stamp color.
 - Use the **Opacity** option to set the opacity percentage.

Fit the image stamp inside the selection box and to adjust the opacity of the stamp

In the center pane of the **Numbering and Stamps** pane, you will have controls to adjust the image stamp to fit inside the selection box and the opacity of the stamp.

- To adjust the stamp inside the selection box, do one of the following;
 - Use the four-arrow icon to fit the image entirely within the box you have drawn (the selection box).
 - Use the **Scale** option to scale the image by a percentage within the selection box.
 - Use the **Rotation** option to rotate the image by **0**, **90**, **180**, or **270** degrees, or type in a custom rotation.
 - The **Left** and **Top** controls offset the image within the selection box. **Top** specifies the distance of the image from the top of the box; **Left** specifies the distance of the image from the left side of the box.

Note: **Opacity** refers to the opacity of the stamp, but you can also set the opacity of the background color.

Add tabs

You can insert a tab before each bookmarked page of selected level or before a chapter start page.

To insert tabs at PDF bookmark locations, the imported job must be an Acrobat PDF with bookmarks already specified in the document. To insert tabs at chapter starts, add the chapter starts in Fiery JobMaster. You must have an activated Fiery JobMaster license.

- 1 Import a PDF job into the **Held** queue of Command WorkStation.
- 2 From the **Held** queue, select a job and do any one of the following:
 - From the **Actions** menu, select **JobMaster**.
 Right-click and select **JobMaster**.
- 3 From the **View** menu, select **Show Bookmarks**.
 The PDF bookmarks are shown with a red ribbon.
- 4 To add chapter starts to the PDF, select a page and choose **Chapter Start** from the **Actions** menu.
 Chapter starts are shown with a blue ribbon. If a page is both a bookmark and a chapter start, it is shown with a blue and red ribbon.
- 5 From the **Actions** menu, go to **Chapter and Bookmark Actions** and select one or more of the following:

Option	Description
Convert Bookmarks to Tabs	All bookmarked pages of a selected level, or all chapter start pages are converted to tabs. The Edit Tab window will automatically open; the tab text fields will be automatically populated with each bookmark's title. This is enabled only if the imported PDF has bookmarks or if chapter starts are set.
Insert Tab	A tab will be inserted before each bookmarked page of a selected level, or before a chapter start page. The Edit Tab window will automatically open; the tab text fields will be automatically populated with each bookmark's title. This is enabled only if the imported PDF has bookmarks or if chapter starts are set.
Insert Text	A bookmark title will be inserted into all pages of a selected bookmark level. The Numbering and Stamps pane will automatically open, and the tab text fields will be automatically populated with each bookmark's title. This is enabled only if the imported PDF has bookmarks and is not available for chapter start pages.

Note:

- Fiery JobMaster supports up to six levels of PDF Bookmarks.
- If two or more bookmarks of the same level appear on a page, only the first bookmark is used.
- If there are two or more levels of bookmarks on a page, only the top-level bookmark is honored. For example, if there are bookmarks of level 1 and level 2 on a page and you select a level 2 bookmark, the Chapter and Bookmark Actions feature will ignore this page.
- Longer bookmark titles that cannot fit in the tab ear text field appear to be cut off from both ends.
- Multi-bank tab functionality is not supported. If multiple tab sets are supported on your Fiery server, tabs are always inserted in the first set.
- All tabs inserted using **Chapter and Bookmark Actions** will have the same tab settings and tab media preset.
- Even if tabs are inserted using **Chapter and Bookmark Actions**, you can use the **Insert Tab** function to insert tabs.

When tabs have been added to a document, you can use the **Filter Tabs** icon in the **Page View** tool bar to display only those pages with tabs.

Insert and edit tabs in Fiery JobMaster

If tab printing is supported by the Fiery server, you can insert tabs and specify text and media settings for them. In the **Tab Media** window you can save media settings as a preset. You can define custom tabs and those settings are included in the preset.

You can specify two tab styles in a single document. This allows you to identify chapters and sub-chapters in long documents. See [Add multiple tab styles to a document](#) on page 114.

The **Tab Media** window displays an image of the tab ear with measurements. When you change the number of tabs in a set, the measurements shown in the displayed tab change. You can specify up to 50 tabs in a set.

To convert a normal page to a tabbed page, select the page's **Convert to tab** option.

- 1 Right-click a spooled job in Command WorkStation, and choose **JobMaster**.
- 2 To insert a tab, select a page or pages in the **Page View** pane, and click **Actions > Insert Tab**.
- 3 To edit a tab, right-click it in the **Page View** or **Sheet View** pane, and click **Edit Tab**.
- 4 Specify settings in the **Edit Tab** window.
 - **Text** - If you have more than one tab in your document, select the tab to specify settings for it. When you add text to a tab, you can select the next or previous tab by pressing **ctrl+right arrow** (Windows) or **cmd+right arrow** (macOS).
 - **Background Color** - Click the **Disabled** button to enable.
 - **Background Image** - A background image can be a BMP, JPEG (JPG), PNG, TIFF (TIF), or GIF file. When you select a background image to place on the tab, you can specify opacity, scale, and rotation, and set margins relative to the tab size.

- 5 To specify media settings, click the **Edit** button beside the **Media Preset** field, and specify settings:
 - **Tab sequence** - Indicates the order in which the tabs are printed.
 - **Output tray to kick out unused tabs** - Use this setting if you are printing a job that does not use all the tabs in the set. For instance, if you are using only three tabs of a five-tab set, the two unused tabs will be output to the tray you select.
 - **Tab shift (Convert to Tab)** - Use for tabs that have been converted from an existing page.
- 6 (Optional) To save the media settings as a preset, click the **Save Preset** icon next to the **Media Preset** menu and name the preset.
 Presets are displayed in the **Tab Media** window and the **Edit Tab** window.
Note: By default, custom media presets in the **Tab Media** window are sorted in alphanumeric ascending order.
- 7 Click **OK** in the **Tab Media** window.
- 8 Click **OK** in the **Edit Tab** window.
 When tabs have been added to a document, you can use the **Filter Tabs** icon in the **Page View** tool bar to display only those pages with tabs.

Add multiple tab styles to a document

You can add multiple tab styles to a document in Fiery JobMaster, if your printer supports the feature. You can nest the different tab styles also, if your printer supports the feature.

Import the spooled job into Fiery JobMaster.

You can create multiple tab styles and then either insert tabs or convert existing pages to tabs in a single job, and assign the tab styles.

- 1 Do one of the following in the **Page View** pane:
 - To convert an existing page in your document, right-click and select **Convert to Tab**.
 - To insert a new tab, right-click a page and select **Insert Tab**. The tab is inserted as the page before.

If your printer supports multiple tab styles, the available tab styles are listed. You can also create a new tab style by clicking **Create New** if the option is available.
- 2 Select a tab style for your selected tab style.
- 3 Continue to add tabs and select one of the available styles. In addition, you can do the following:
 - To change the tab media, right-click a tab page, and select **Change Tab Media**.
 - Right-click a tab page, and select **Edit Tab** to make changes to the tab style. See [Insert and edit tabs in Fiery JobMaster](#) on page 113.
 - Choose to nest multiple tab sets by selecting **Nest multiple tab sets** in the **Edit Tab** window.
Note: If you choose not to select this option, each of the tab styles will be assigned sequentially wherever they are in the job. See the example below.
- 4 To view the information about the tab style selected for a specific page, click on the tab page.

The tab style information uses the following terminology:

- Tab ear - a single ear that sticks out from the edge of the media
- Tab bank - a single series of tab ears that often spans the media edge
- Tab cut - the position of the tab within a tab bank
- Tab set - multiple banks with the same tab styles that make up a tab set
- Tab style - media attributes of the tab set (number of ears, first tab offset, reading order)

When you choose to nest multiple tab styles in a single job, the tabs using the second tab style selected will be nested within the first tab style's bank of tabs. For instance, you assign Tab Bank 1 with 3 sets of tabs to the first two tabs in the job. You then assign Tab Bank 2 with 5 sets of tabs to the third and fourth tabs in the job. When you assign the fifth tab in the job to Tab Bank 1, the tab will be position number 3 in that bank. If you then assign the sixth tab in the job to Tab Bank 2, the tab will be position number 1 in that bank. If you move the first tab of Tab Bank 2 before the first tab of Tab Bank 1 in the job, then Tab Bank 2 becomes the primary style, and Tab Bank 1 is nested within Tab Bank 2. Unused tabs in a bank will use the **Output tray to kick out unused tabs** option in the **Tab Media** window.

If you choose not to nest multiple tab styles in a single job, then the tabs for each tab style will be assigned sequentially in the job. Then, using the Tab Bank 1 and Tab Bank 2 example above, the sixth tab in the job which has been assigned to Tab Bank 2 will be position number 3 in that tab bank.

Bleed edge tabs in Fiery JobMaster

Bleed edge tabs are printed on the page itself, not on tabs. The tabs bleed 1/8-inch beyond the defined edge of the page based on the trim box. You can position bleed edge tabs anywhere and specify different content for each set of tabs.

The bleed edge tabs are applied to pages in the document. When pages are added or removed before the pages with the bleed edge tabs, the page ranges in the bleed edge tabs **List** view are updated to reflect the new position of the original pages in the job. When pages are inserted between, or removed from, pages listed in a bleed edge tab page range, the page range changes to reflect the changed pages.



Bleed edge tabs cannot be added to the following types of pages in a job:

- Inserted sheets
- Inserted tabs
- Implicit blanks
- Pages converted to tabs

When adding bleed edge tabs to a job, first specify the content of the bleed edge tabs, and then the position of the tabs. You can preview the settings for both content and position.

Tools in Bleed Edge Tabs window

The **Bleed Edge Tabs** window provides several tools, including the following:

-  - selects the image.
-  - moves the image.
-  - select a zoom percentage, or click the icon to fit the page to the preview window.

You can also page through the document by using the navigation arrows or entering a page number in the page text field.

Add content to bleed edge tabs

In Fiery JobMaster you can define sets of bleed edge tabs, add styled text, and add background color and images.

- 1 Select a job in the Command WorkStation **Held** list and choose **Actions > JobMaster**.
- 2 Select any page of the job in the **Page View** pane and choose **Actions > Edit Bleed Edge Tab**.
 As you specify settings in the **Bleed Edge Tabs** window, you can preview your settings by clicking **Preview**.
- 3 In the **Bleed Edge Tabs** window, select the **Content** tab, and then select **List**.
- 4 Specify the ranges for the bleed edge tabs by entering the page numbers in the **From** and **To** fields. Press **Enter** to create a row for the next set.
 Page ranges must be sequential and cannot overlap. You can skip some pages for chapter beginnings. To delete a page range, select the range and the minus button at the bottom of the window.
- 5 To specify text for all bleed edge tabs in a range, select a range and enter text in the **Type** text field. Specify text settings such as font and orientation.
- 6 To add a background fill, select a color and percentage opacity.
 To enable the **Background** option, click the **Disabled** button.
- 7 To add an image to all tabs, click the **Disabled** button to enable the **Image** area, and browse to select an image.
 The image can be in BMP, JPEG, TIFF, TIF, GIF, or PNG format. You can also specify settings such as opacity and set margins relative to the tab size.
- 8 Click the **Apply styles to all** button to specify which styles you want to apply to which sets of tabs.
 By default, styles apply only to the tabs in the current section. Selecting **Apply styles to tabs of the same position** also applies the checked items to all tab sections that are in the same tab position.

Specify position of bleed edge tabs

In the Fiery JobMaster **Bleed Edge Tabs** window, you can specify the position of the bleed tabs in the final output. The position you specify applies to all the tabs in the job.

- 1 Select a job in the Command WorkStation **Held** list and choose **Actions > JobMaster**.
- 2 Select any page of the job in the **Page View** pane and choose **Actions > Edit Bleed Edge Tab**.
- 3 In the **Bleed Edge Tabs** window, select the **Position** tab.

4 Specify settings. To preview your settings, click **Preview** at any time.

- **Number of tabs** - Specify up to 99 tabs.
- **Media Size** - Changes media size for output, and changes preview.

Note: The trimbox value specifies that the bleed edge tabs are placed along the trimbox by the side of the document, as defined in the original PDF file or in trimbox settings in the **Edit Page** feature.

- **Printing Area** - Use **Auto** to base the tab ear's height and width on the media size, number of tabs, and distances between the tabs. Use **Custom** to specify a different height and width.
- **Repeat Style** - Changes the pattern of how tabs are placed on the pages.

Image Editing

This feature launches a third-party image editor application so that you can edit an imported scanned page.

The default application to edit bitmap images is Microsoft Paint for Windows and Preview for macOS.

You can override the default application in the **JobMaster** tab of the **Preferences** window. The **Edit Image Application** dropdown list displays the available applications.

For example, if Microsoft Paint is set as the default application, **Edit in Paint** is available as an option when you right-click a page in the **Page View** pane.

The following limitations apply:

- This feature is available only for pages that contain one scanned image with no other content.
- The edited image must be saved using the same filename and file type as the original image or Fiery JobMaster will not be able to detect the saved file.
- The edited image must be a flattened image file. Addition of layers or objects by the image-editing application is not supported.
- Fiery JobMaster supports most of the commonly used image editing functions. External image-editing applications may support some features that are not compatible with Fiery JobMaster.

